

CAPSULE N.1

SKINGLASS
SINGLE
FREESTANDING
COMPLEMENTS
FRAME
COLOURS



CO CERASA®

CAPSULE N.1

SKINGLASS

SINGLE

FREESTANDING

COMPLEMENTS

FRAME

COLOURS

CO CERASA®

DIAMO NUOVE FORME AL FUTURO



—→ Saper interpretare con proposte sempre nuove ed originali gli spazi, gli stili di vita e la contemporaneità fa parte del DNA di Cerasa. Ricerca e creatività prendono vita anche nell'ideazione di progetti dedicati a specifiche esigenze dei nostri clienti, la cui soddisfazione ci fa da guida e ci ispira ogni giorno. Così è nato Skinglass, l'innovativa collezione di rivestimenti, insieme ai nuovi prodotti Single, Frame ed altri interessanti articoli ad integrazione delle collezioni esistenti. Soluzioni agili ed eclettiche, dalla forte personalità e flessibilità. Dai termoarredi ai lavabi freestanding, tutti personalizzabili con numerose finiture o con i rivestimenti e decori Cerasa. I nuovi mobili monoblocco Single sono adatti a risolvere spazi e volumi assieme, un connubio vincente tra estetica e capacità contenitiva. Nessun dettaglio qualitativo viene mai tralasciato, nel rispetto della nostra identità e dei desideri del nostro pubblico. Continuiamo a dare nuove forme al futuro della sala da bagno attraverso prodotti e soluzioni che sanno sempre stupire.

EN SHAPING
THE FUTURE IN
A NEW WAY

Knowing how to interpret space, lifestyle and the requirements of contemporary living with ever new and original designs is an integral part of Cerasa's DNA.

Research and creativity are the essential ingredients in the design of projects dedicated to the specific needs of our customers, whose satisfaction guides us and inspires us every day. This is how the Skinglass exclusive finish was created, alongside the new products Single, Frame and other interesting articles that complement existing collections. Flexible and eclectic solutions that are versatile and unique.

From heated towel rails to freestanding washbasins, all our designs can be customized with a variety of Cerasa finishes, coatings and decorations.

The new Single bathroom one-piece unit is perfect for solving the use of space and volumes through a winning combination of storage capacity and aesthetics. No detail is left out in achieving the quality that defines our identity and is designed to meet our customer's requirements. We continue to give new shapes to the future of bathroom fittings through consistently remarkable products and solutions.

FR NOUS DONNONS
DE NOUVELLES FORMES
AU FUTUR

Savoir interpréter les espaces, les styles de vie et l'époque actuelle avec des propositions toujours nouvelles et originales fait partie de l'ADN de Cerasa.

La recherche et la créativité prennent également vie dans la conception de projets dédiés à des exigences spécifiques de nos clients, dont la satisfaction nous inspire et nous guide chaque jour. C'est ainsi qu'est né Skinglass, le revêtement innovant, avec les nouveaux produits Single, Frame et d'autres articles intéressants qui viennent compléter les collections existantes.

Ce sont des solutions agiles et éclectiques, caractérisées par une forte personnalité et une grande souplesse.

Des radiateurs décoratifs aux lavabos autoportants, tous personnalisables avec de nombreuses finitions ou avec les revêtements et les décorations Cerasa. Les nouveaux meubles monoblocs Single, qui permettent d'apporter une solution à la fois aux espaces et aux volumes, sont une combinaison gagnante d'esthétique et de capacité de rangement. Aucun détail concernant la qualité n'est oublié, jamais, dans le respect de notre identité et des désirs de notre public. Nous continuons à donner de nouvelles formes au futur de la salle de bains grâce à des produits et des solutions qui étonnent toujours.

INDEX

SKINGLASS	7
SINGLE	91
FREESTANDING	101
Colonna	103
Totem	104
COMPLEMENTS	117
Specchi/Mirrors/Miroirs	118
Vasche/Bathtubs/Baignoires	119
Paravento e Servomuto/Folding screen and valet stand/Paravent et valet	120
Colonna/Full-height unit/Colonne	124
FRAME	127
COLOURS	135
COLLECTIONS	138
RECAP	

—→ Skinglass identifica la nuova collezione di rivestimenti grafici, realizzati in fibra di vetro, carta da parati vinilica e tessuto, proposti sia per la sala da bagno sia per le zone notte e living. L'innovativo rivestimento in fibra di vetro EQ•dekor[®], realizzato da Mapei in collaborazione con Inkiostro Bianco, può essere applicato negli spazi in cui acqua, umidità e vapore richiedono materiali tecnologicamente resistenti; tale prodotto garantisce una protezione integrale e antisismica, in quanto certificato per fungere da legante strutturale. Con le medesime grafiche vi è la variante in carta da parati vinilica, lavabile e più performante rispetto alla cellulosa, e il tessuto, da utilizzare nei complementi d'arredo.

EN Skinglass embodies the new collection of graphic coverings, realised in fiber glass, vinyl wallpaper and fabric, proposed both for the bathroom and for the night zone and living areas. The innovative EQ•dekor[®] fiber glass coating, realised by Mapei in collaboration with Inkiostro Bianco, is designed for spaces where water, moisture and steam require use of technologically resistant materials; this product guarantees a full and anti-seismic protection, as it is certified to act as a structural binder. Also available with the same decorative patterns is a washable vinyl wallpaper variant, offering a superior performance compared to ordinary cellulose, and fabric, to be used on furnishing accessories.

FR Skinglass identifie la nouvelle collection de revêtements graphiques, réalisés en fibre de verre, papier peint vinyle et tissus, proposés aussi bien pour les salles de bains que pour les zones nuit et living. L'innovant revêtement en fibre de verre EQ•dekor[®], réalisé par Mapei en collaboration avec Inkiostro Bianco, a été conçu pour être appliqué dans les endroits où l'eau, l'humidité et la vapeur nécessitent l'utilisation de matériaux technologiquement résistants; ce produit garantit une protection intégrale et antisismique, car il est certifiée capable de servir de liant structurel. Il existe, avec les mêmes graphismes, une variante en papier peint vinyle, lavable elle aussi, qui offre des performances supérieures à celles de la cellulose normale, et le tissu, à utiliser sur les accessoires d'ameublement.

SKINGLASS

WATERPROOF
DESIGN

CO CERASA[®]



→ SKINGLASS:
L'INNOVAZIONE
CHE ARREDA

→ SKINGLASS:
INNOVATIVE FURNISHING
SOLUTIONS

→ SKINGLASS:
L'INNOVATION
QUI MEUBLE

IT Materiali e metodo di posa di ultima generazione permettono dei rivestimenti, oltre che in particolari situazioni come interni doccia, pavimento o soffitto, anche su appositi lavabi Cerasa e frontali dei mobili della collezione DES: una novità che si appresta a modificare il nostro modo di abitare creando dei veri e propri percorsi di arredo. Un abito nuovo per le superfici, una seconda pelle resistente e sicura, impermeabile come solo il vetro sa essere. Skinglass nasce e diventa protagonista attraverso un'elaborata proposta grafica, che spazia dagli elementi minimal fino ai decori più esuberanti, creazioni decorative definite appositamente da Cerasa e condivise con una azienda di riferimento come Inkiostro Bianco le cui tecnologie produttive e il proprio know how si riversano in queste proposte capaci di creare un nuovo concetto di bagno, ricco di suggestioni ed emozioni.

EN Latest generation materials and laying method provide protection for shower cabinets, floor or ceiling, as well as for Cerasa washbasins and front panels for the base units in the DES collection: new products and finishes that will surely change the way we inhabit space through innovative furnishing solutions. A safe and resistant material for surfaces that feels like a second skin, waterproof as only glass can be. Skinglass was created to offer a variety of decorative designs, ranging from minimal elements to the most exuberant decorations. Specially designed by Cerasa, they are produced in partnership with the leading company Inkiostro bianco, whose production technologies and know-how have contributed to shape products capable of radically improve the look and charm of your bathroom.

FR Les matériaux et la méthode de pose de dernière génération permettent de réaliser des revêtements non seulement dans des situations particulières, telles que l'intérieur des douches, les sols ou les plafonds, mais aussi sur certains lavabos et certaines vasques Cerasa, ainsi que sur les façades des meubles de la collection DES : une nouveauté qui est appelée à modifier rapidement notre façon d'habiter en créant de véritables parcours d'ameublement. Un nouvel habillage pour les surfaces, une deuxième peau résistante et sûre, imperméable, comme seul le verre peut l'être. Skinglass étonne grâce à ses propositions graphiques élaborées, qui sont aussi bien des éléments minimalistes que des décorations exubérantes. Ce sont des créations décoratives spécialement définies par Cerasa et partagées avec une entreprise de référence comme Inkiostro Bianco, dont les technologies de production et le savoir-faire sont présentes dans ces propositions capables de créer un nouveau concept de salle de bains plein de sensations et d'émotions.

DIAMOND

↓ Collection
SINGLE/CARTABIANCA



Fibra di vetro
Fiber glass
Fibre de verre
ZC KCR M11 05 99

Carta da parati vinilica
Vynil wallpaper
Papier peint vinyle
ZC KCR M11 00 99

A



Fibra di vetro
Fiber glass
Fibre de verre
ZC KCR M21 05 99

Carta da parati vinilica
Vynil wallpaper
Papier peint vinyle
ZC KCR M21 00 99

B





↑ Collection
NEROLAB

MAGNOL

↓ Collection
CARTABIANCA/NEROLAB
FRAME



Fibra di vetro
Fiber glass
Fibre de verre
ZC KCM G21 05 99

Carta da parati vinilica
Vinyl wallpaper
Papier peint vinyle
ZC KCM G21 00 99

A



Fibra di vetro
Fiber glass
Fibre de verre
ZC KCM G11 05 99

Carta da parati vinilica
Vinyl wallpaper
Papier peint vinyle
ZC KCM G11 00 99

B



↑ Collection
NEROLAB

GREENGLASS



Fibra di vetro
Fiber glass
Fibre de verre
ZC KCG G11 05 99

Carta da parati vinilica
Vynil wallpaper
Papier peint vinyle
ZC KCG G11 00 99

A



Fibra di vetro
Fiber glass
Fibre de verre
ZC KCG G21 05 99

Carta da parati vinilica
Vynil wallpaper
Papier peint vinyle
ZC KCG G21 00 99

B



↓ Collection
NEROLAB/SEGNO
FRAME

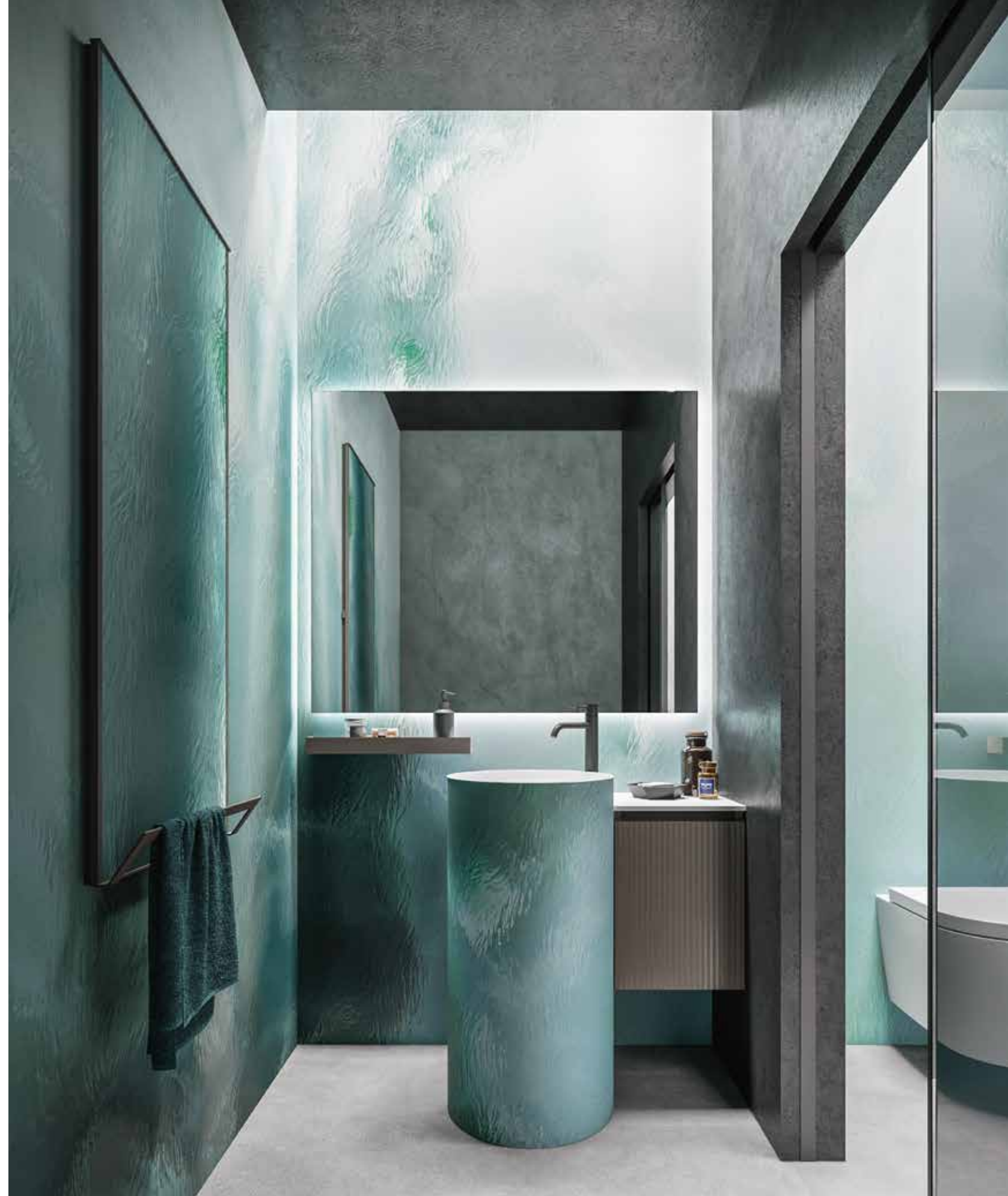

BAYOU

↓ Collection
DES



Fibra di vetro
Fiber glass
Fibre de verre
ZC KCB Y11 05 99

Carta da parati vinilica
Vinyl wallpaper
Papier peint vinyle
ZC KCB Y11 00 99

A



Fibra di vetro
Fiber glass
Fibre de verre
ZC KCB Y21 05 99

Carta da parati vinilica
Vinyl wallpaper
Papier peint vinyle
ZC KCB Y21 00 99

B



↑ Collection
NEROLAB

CORAL



Fibra di vetro
Fiber glass
Fibre de verre
ZC KCC R11 05 99

Carta da parati vinilica
Vynil wallpaper
Papier peint vinyile
ZC KCC R11 00 99

A



Fibra di vetro
Fiber glass
Fibre de verre
ZC KCC R21 05 99

Carta da parati vinilica
Vynil wallpaper
Papier peint vinyile
ZC KCC R21 00 99

B

↓ Collection
EDEN



VESUVIO

↓ Collection
DES



Fibra di vetro
Fiber glass
Fibre de verre
ZC KCV SV1 05 99

Carta da parati vinilica
Vynil wallpaper
Papier peint vinyle
ZC KCV SV1 00 99

A



Fibra di vetro
Fiber glass
Fibre de verre
ZC KCV S21 05 99

Carta da parati vinilica
Vynil wallpaper
Papier peint vinyle
ZC KCV S21 00 99

B





↑ Collection
NEROLAB

FLUID



Fibra di vetro
Fiber glass
Fibre de verre
ZC KCF D11 05 99

Carta da parati vinilica
Vinyl wallpaper
Papier peint vinyle
ZC KCF D11 00 99

A

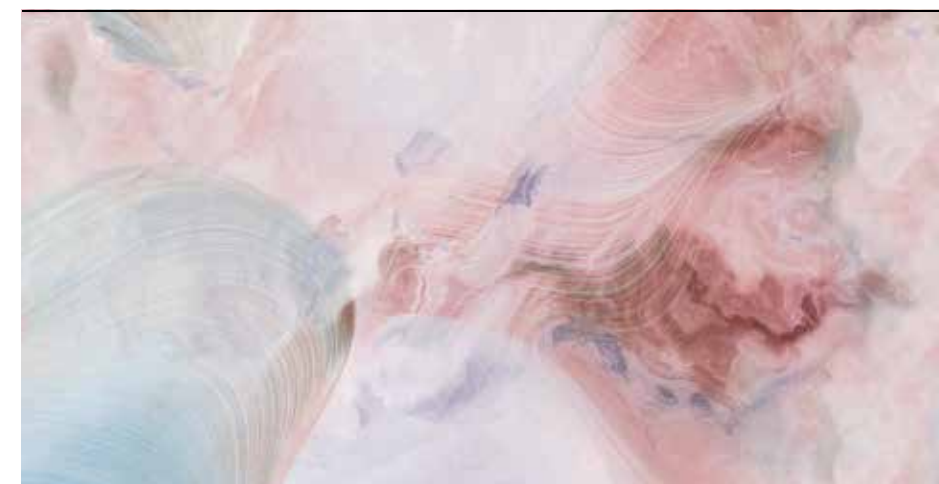

Fibra di vetro
Fiber glass
Fibre de verre
ZC KCF D21 05 99

Carta da parati vinilica
Vinyl wallpaper
Papier peint vinyle
ZC KCF D21 00 99

B

PEACOCK

↓ Collection
NEROLAB



Fibra di vetro
Fiber glass
Fibre de verre
ZC KCP K11 05 99

Carta da parati vinilica
Vynil wallpaper
Papier peint vinyle
ZC KCP K11 00 99

A



Fibra di vetro
Fiber glass
Fibre de verre
ZC KCP K21 05 99

Carta da parati vinilica
Vynil wallpaper
Papier peint vinyle
ZC KCP K21 00 99

B



↓ Collection
DES





↑ Collection
MAORI

GEOFLO



Fibra di vetro
Fiber glass
Fibre de verre
ZC KCG F11 05 99

Carta da parati vinilica
Vynil wallpaper
Papier peint vinyle
ZC KCG F11 00 99

A



Fibra di vetro
Fiber glass
Fibre de verre
ZC KCG F21 05 99

Carta da parati vinilica
Vynil wallpaper
Papier peint vinyle
ZC KCG F21 00 99

B

↓ Collection
DES





↑ Collection
SUEDE

JELLYFISH



Fibra di vetro
Fiber glass
Fibre de verre
ZC KCJ F11 05 99

Carta da parati vinilica
Vynil wallpaper
Papier peint vinyle
ZC KCJ F11 00 99

A



Fibra di vetro
Fiber glass
Fibre de verre
ZC KCJ F21 05 99

Carta da parati vinilica
Vynil wallpaper
Papier peint vinyle
ZC KCJ F21 00 99

B





↑ Collection
DES

VERTICAL

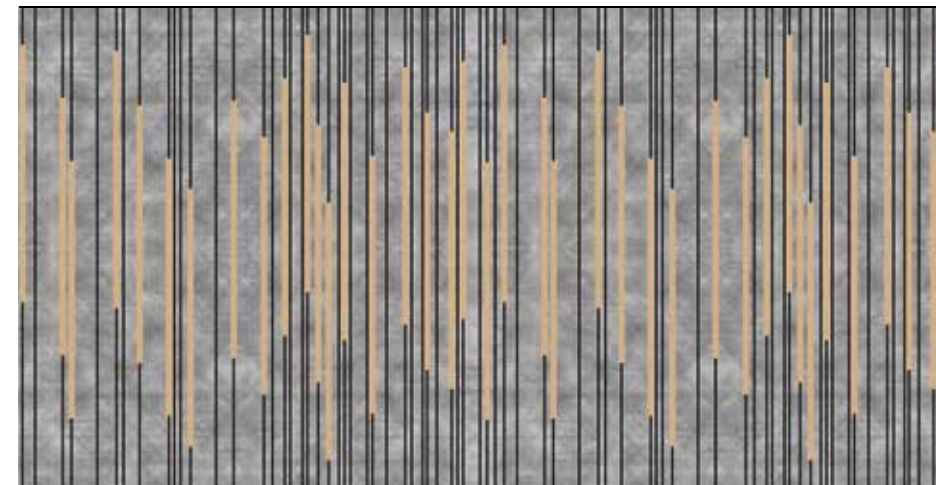

Fibra di vetro
Fiber glass
Fibre de verre
ZC KCV T11 05 99

Carta da parati vinilica
Vynil wallpaper
Papier peint vinyle
ZC KCV T11 00 99

A

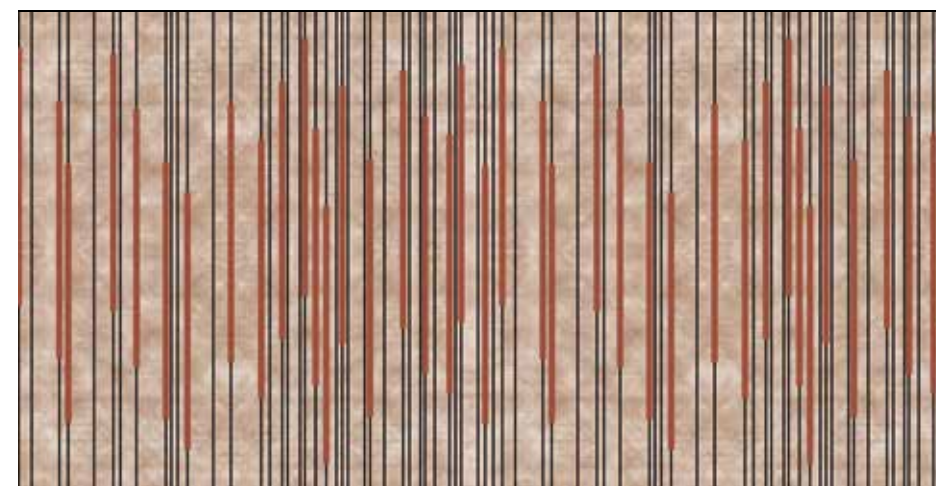

Fibra di vetro
Fiber glass
Fibre de verre
ZC KCV T21 05 99

Carta da parati vinilica
Vynil wallpaper
Papier peint vinyle
ZC KCV T21 00 99

B

RAINFOREST

↓ Collection
MAORI



Fibra di vetro
Fiber glass
Fibre de verre
ZC KCJ C11 05 99

Carta da parati vinilica
Vinyl wallpaper
Papier peint vinyle
ZC KCJ C11 00 99

A



Fibra di vetro
Fiber glass
Fibre de verre
ZC KCJ C21 05 99

Carta da parati vinilica
Vinyl wallpaper
Papier peint vinyle
ZC KCJ C21 00 99

B





↑ Collection
DIES



↑ Collection
DES
FRAME

RUST



Fibra di vetro
Fiber glass
Fibre de verre
ZC KCR S11 05 99

Carta da parati vinilica
Vynil wallpaper
Papier peint vinyle
ZC KCR S11 00 99

A

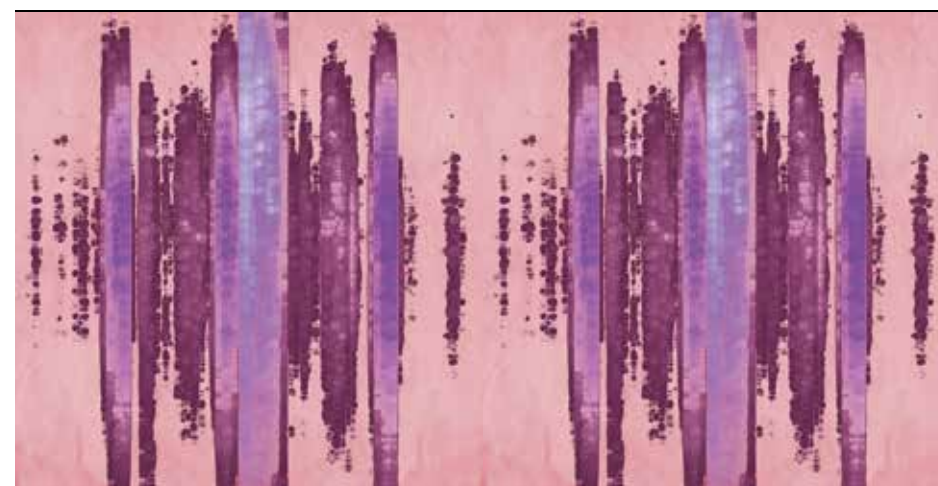

Fibra di vetro
Fiber glass
Fibre de verre
ZC KCR S41 05 99

Carta da parati vinilica
Vynil wallpaper
Papier peint vinyle
ZC KCR S41 00 99

B

FLOWER

↓ Collection
NEROLAB
FRAME



Fibra di vetro
Fiber glass
Fibre de verre
ZC KCF RA1 05 99

Carta da parati vinilica
Vinyl wallpaper
Papier peint vinyle
ZC KCF RA1 00 99

A



Fibra di vetro
Fiber glass
Fibre de verre
ZC KCF R21 05 99

Carta da parati vinilica
Vinyl wallpaper
Papier peint vinyle
ZC KCF R21 00 99

B





↑ Collection
DES



↑ Collection
DES

PLANS



Fibra di vetro
Fiber glass
Fibre de verre
ZC KCP L21 05 99

Carta da parati vinilica
Vynil wallpaper
Papier peint vinyle
ZC KCP L21 00 99

A



Fibra di vetro
Fiber glass
Fibre de verre
ZC KCP L11 05 99

Carta da parati vinilica
Vynil wallpaper
Papier peint vinyle
ZC KCP L11 00 99

B

FOLD

↓ Collection
DES
FRAME

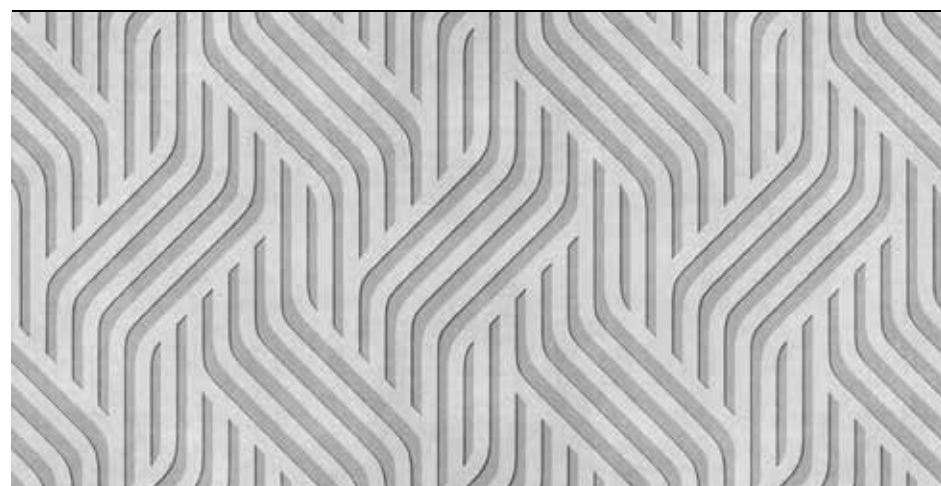

Fibra di vetro
Fiber glass
Fibre de verre
ZC KCF 031 05 99

Carta da parati vinilica
Vynil wallpaper
Papier peint vinyle
ZC KCF 031 00 99

A



Fibra di vetro
Fiber glass
Fibre de verre
ZC KCF 011 05 99

Carta da parati vinilica
Vynil wallpaper
Papier peint vinyle
ZC KCF 011 00 99

B





↑ Collection
FREE

BLOSSOM

↓ Collection
DES



Fibra di vetro
Fiber glass
Fibre de verre
ZC KCG L21 05 99

Carta da parati vinilica
Vinyl wallpaper
Papier peint vinyle
ZC KCG L21 00 99

A



Fibra di vetro
Fiber glass
Fibre de verre
ZC KCG LM1 05 99

Carta da parati vinilica
Vinyl wallpaper
Papier peint vinyle
ZC KCG LM1 00 99

B





↑ Collection
NEROLAB
FRAME

GRAPHITE



Fibra di vetro
Fiber glass
Fibre de verre
ZC KCG R11 05 99

Carta da parati vinilica
Vinyl wallpaper
Papier peint vinyle
ZC KCG R11 00 99

A



Fibra di vetro
Fiber glass
Fibre de verre
ZC KCG R21 05 99

Carta da parati vinilica
Vinyl wallpaper
Papier peint vinyle
ZC KCG R21 00 99

B



↑ Collection
NEROLAB

WATER LILY



Fibra di vetro
Fiber glass
Fibre de verre
ZC KCN N21 05 99

Carta da parati vinilica
Vynil wallpaper
Papier peint vinyle
ZC KCN N21 00 99

A



Fibra di vetro
Fiber glass
Fibre de verre
ZC KCN N11 05 99

Carta da parati vinilica
Vynil wallpaper
Papier peint vinyle
ZC KCN N11 00 99

B



↓ Collection
FREE



UNDERGROWTH

↓ Collection
DES



Fibra di vetro
Fiber glass
Fibre de verre
ZC KCJ A21 05 99

Carta da parati vinilica
Vynil wallpaper
Papier peint vinyle
ZC KCJ A21 00 99

A



Fibra di vetro
Fiber glass
Fibre de verre
ZC KCJ A11 05 99

Carta da parati vinilica
Vynil wallpaper
Papier peint vinyle
ZC KCJ A11 00 99

B





CAPSULE N.1



SKINGLASS



73

RUINS

↓ Collection
NEROLAB

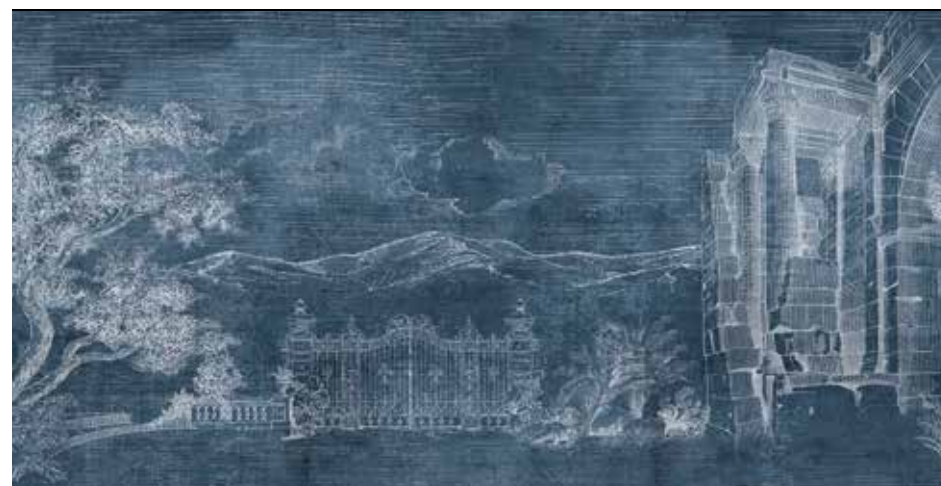

Fibra di vetro
Fiber glass
Fibre de verre
ZC KCR N11 05 99

Carta da parati vinilica
Vinyl wallpaper
Papier peint vinyle
ZC KCR N11 00 99

A

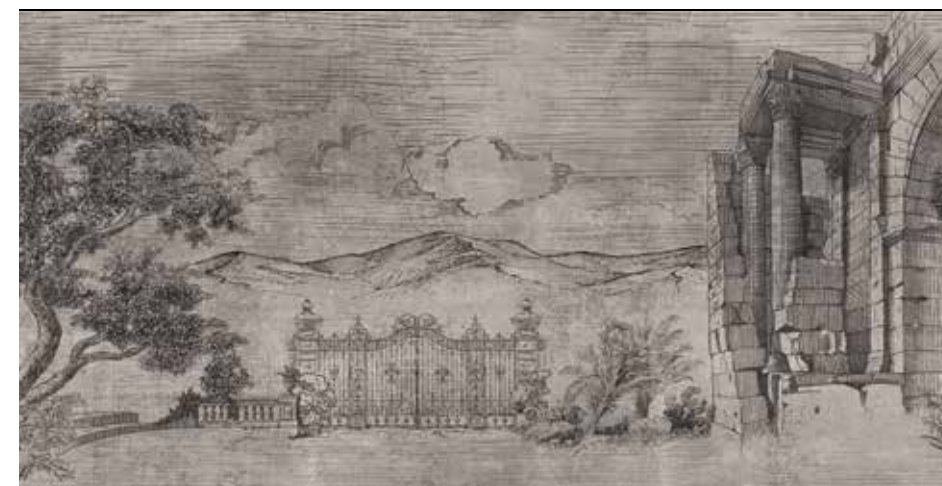

Fibra di vetro
Fiber glass
Fibre de verre
ZC KCR N21 05 99

Carta da parati vinilica
Vinyl wallpaper
Papier peint vinyle
ZC KCR N21 00 99

B



↑ Collection
SUEDE

IT La grande versatilità dei rivestimenti: Skinglass permette di selezionare la porzione di immagine che si preferisce in funzione dello spazio a disposizione.

EN The utmost versatility in coverings: with Skinglass you can choose your favourite image section according to the available space.

FR La grande flexibilité des revêtements : Skinglass permet de sélectionner la portion d'image que l'on préfère en fonction de l'espace disponible.



SHAPES

↓ Collection
NEROLAB

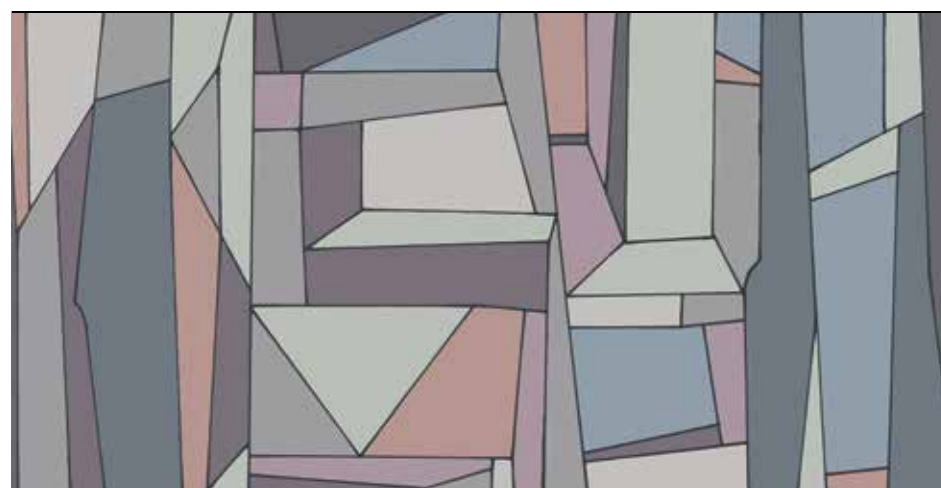

Fibra di vetro
Fiber glass
Fibre de verre
ZC KCS H11 05 99

Carta da parati vinilica
Vynil wallpaper
Papier peint vinyle
ZC KCS H11 00 99

A

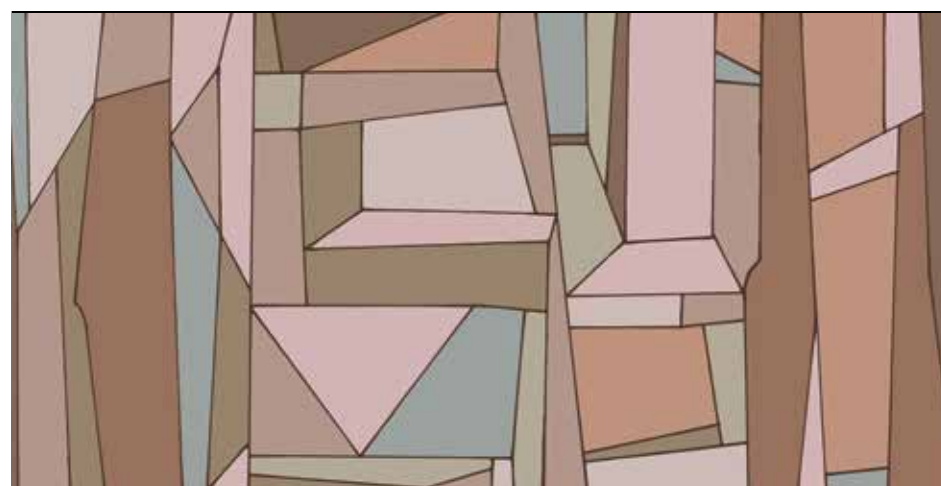

Fibra di vetro
Fiber glass
Fibre de verre
ZC KCS H21 05 99

Carta da parati vinilica
Vynil wallpaper
Papier peint vinyle
ZC KCS H21 00 99

B





↑ Collection
DES

LEAF



Fibra di vetro
Fiber glass
Fibre de verre
ZC KCR I21 05 99

Carta da parati vinilica
Vynil wallpaper
Papier peint vinyle
ZC KCR I21 00 99

A



Fibra di vetro
Fiber glass
Fibre de verre
ZC KCR I11 05 99

Carta da parati vinilica
Vynil wallpaper
Papier peint vinyle
ZC KCR I11 00 99

B

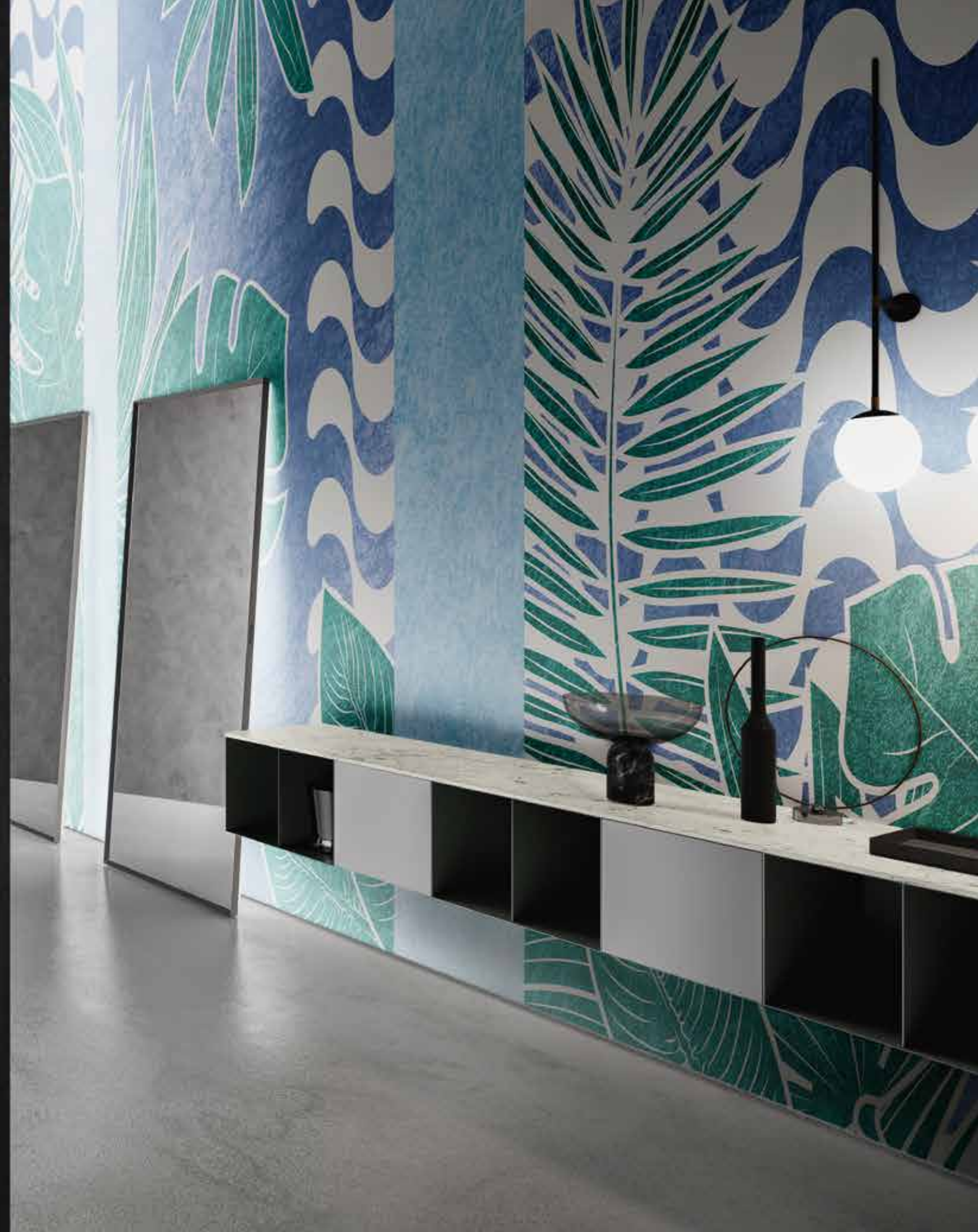

Riepilogo Grafiche/Graphic Summary/Récapitulation des graphismes

▲ Fibra di vetro
Fiber glass
Fibre de verre

■ Carta da parati vinilica
Vinyl wallpaper
Papier peint vinyle

Per calcolo e quotazione vedi P.88
See P.88 for quantities and quotation
Pour le calcul et le prix, voir P.88

DIAMOND

P.10

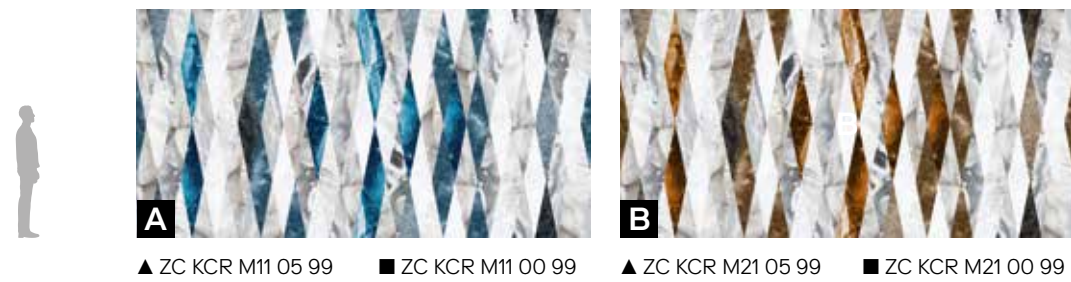

MAGNOL

P.14

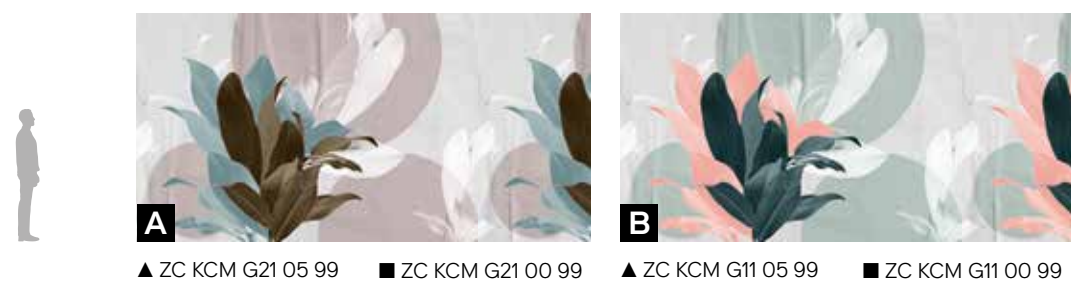

GREENGLASS

P.17

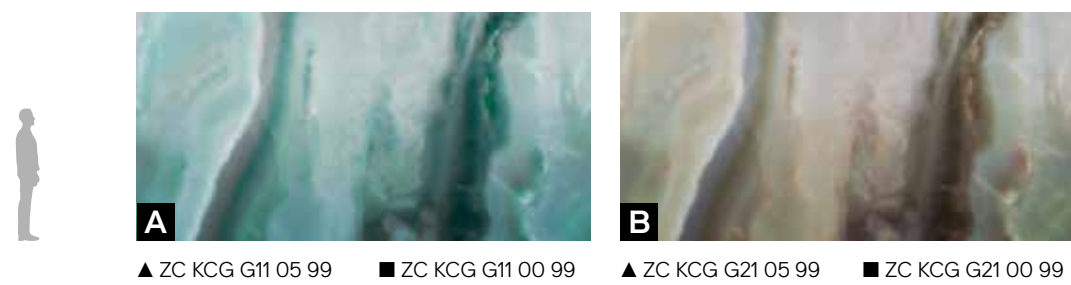

BAYOU

P.20

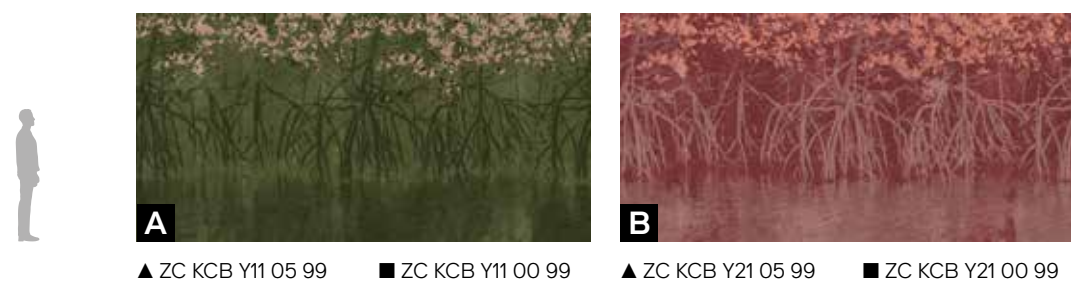

CORAL

P.23

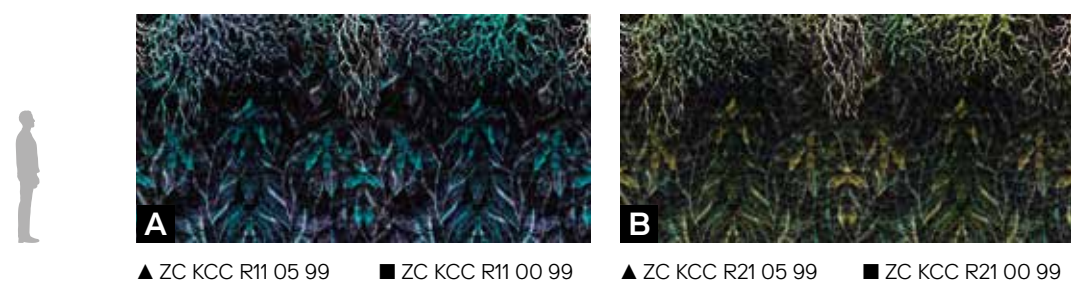

VESUVIO

P.26

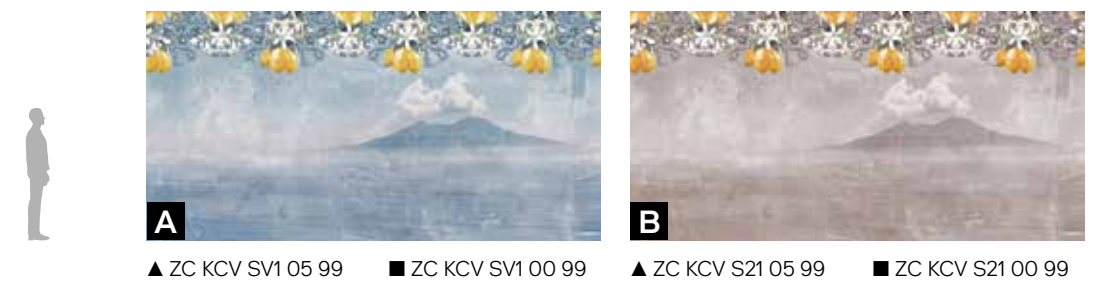

FLUID

P.28

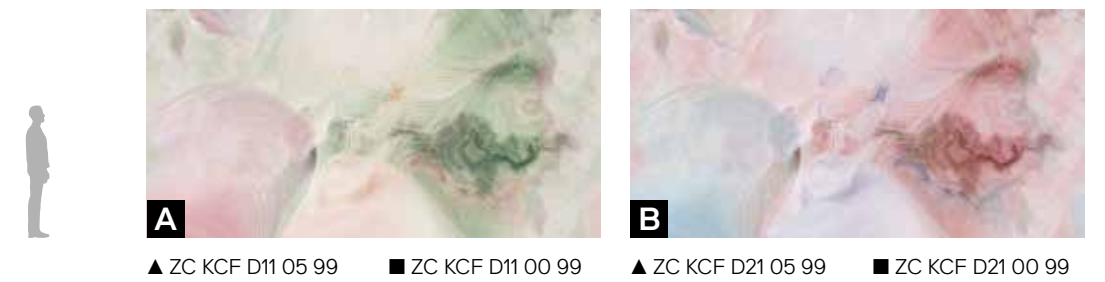

PEACOCK

P.30

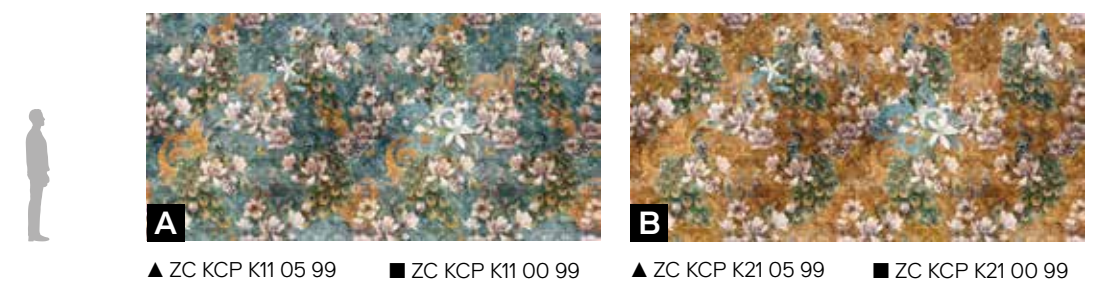

GEOFLO

P.35

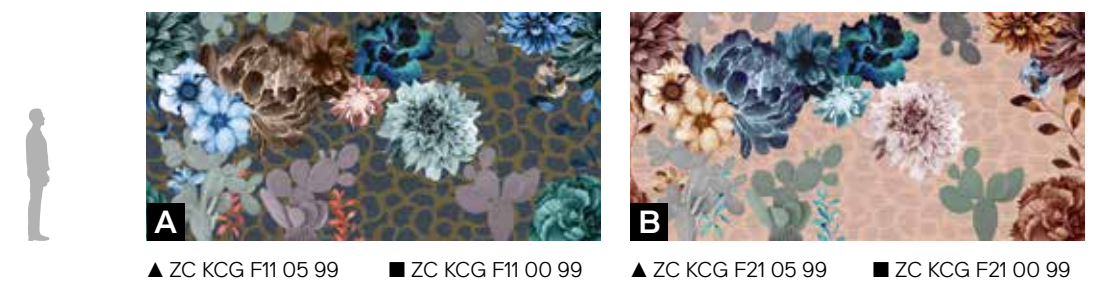

JELLYFISH

P.39

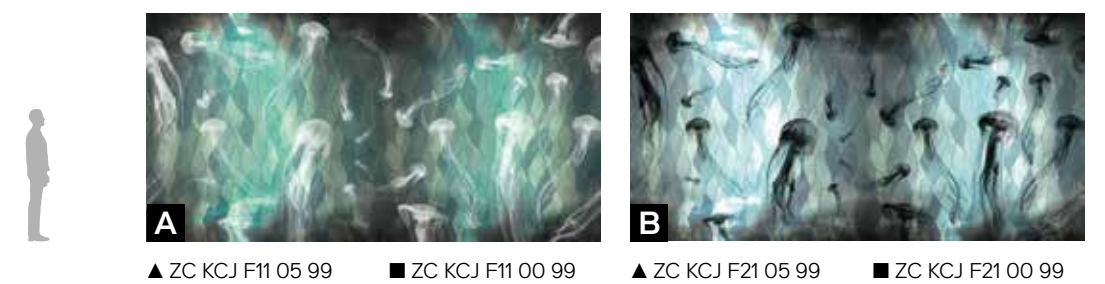

VERTICAL

P.43

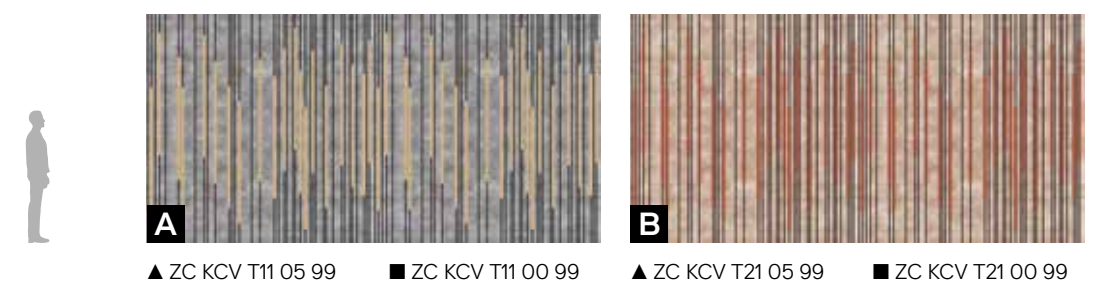

RAINFOREST

P.44



▲ ZC KCJ C11 05 99 ■ ZC KCJ C11 00 99



▲ ZC KCJ C21 05 99 ■ ZC KCJ C21 00 99

RUST

P.49



▲ ZC KCR S11 05 99 ■ ZC KCR S11 00 99



▲ ZC KCR S41 05 99 ■ ZC KCR S41 00 99

FLOWER

P.50



▲ ZC KCF RA1 05 99 ■ ZC KCF RA1 00 99



▲ ZC KCF R21 05 99 ■ ZC KCF R21 00 99

PLANS

P.55



▲ ZC KCP L21 05 99 ■ ZC KCP L21 00 99



▲ ZC KCP L11 05 99 ■ ZC KCP L11 00 99

FOLD

P.56

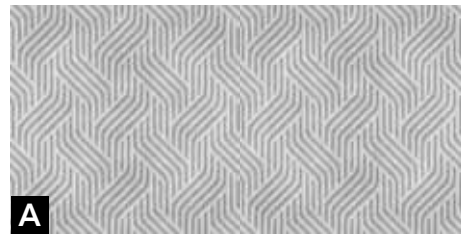

▲ ZC KCF O31 05 99 ■ ZC KCF O31 00 99



▲ ZC KCF O11 05 99 ■ ZC KCF O11 00 99

BLOSSOM

P.60

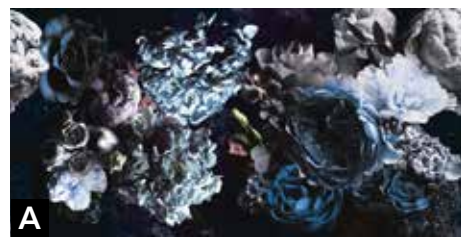

▲ ZC KCG L21 05 99 ■ ZC KCG L21 00 99



▲ ZC KCG LM1 05 99 ■ ZC KCG LM1 00 99

GRAPHITE

P.63



▲ ZC KCG R11 05 99 ■ ZC KCG R11 00 99



▲ ZC KCG R21 05 99 ■ ZC KCG R21 00 99

WATER LILY

P.65



▲ ZC KCN N21 05 99 ■ ZC KCN N21 00 99



▲ ZC KCN N11 05 99 ■ ZC KCN N11 00 99

UNDERGROWTH

P.68



▲ ZC KCJ A21 05 99 ■ ZC KCJ A21 00 99



▲ ZC KCJ A11 05 99 ■ ZC KCJ A11 00 99

RUINS

P.72



▲ ZC KCR N11 05 99 ■ ZC KCR N11 00 99



▲ ZC KCR N21 05 99 ■ ZC KCR N21 00 99

SHAPES

P.76



▲ ZC KCS H11 05 99 ■ ZC KCS H11 00 99



▲ ZC KCS H21 05 99 ■ ZC KCS H21 00 99

LEAF

P.79



▲ ZC KCR I21 05 99 ■ ZC KCR I21 00 99



▲ ZC KCR I11 05 99 ■ ZC KCR I11 00 99

Skerglass fibra di vetro EQ•dekor®/EQ•dekor® fiber glass Skerglass/ Skerglass fibre de verre EQ•dekor®

IT Skerglass nella variante fibra di vetro EQ•dekor® è realizzata in uno speciale tessuto bidirezionale, costituito da fibra di vetro trattata in superficie con una sostanza a base poliuretanica resistente agli alcali. Ne risulta un materiale composito, strutturalmente avanzato, i cui componenti si integrano generando un materiale dalle caratteristiche superiori dal punto di vista fisico, chimico e meccanico, con una resa estetica eccellente. Leggero e maneggevole, il materiale in fibra di vetro EQ•dekor® si adatta con grande flessibilità alla conformazione del suo supporto; per questo può essere applicato a pareti e mobili con grande semplicità. Particolarmente stabile, resistente alle trazioni, alle abrasioni, agli agenti atmosferici e ai raggi ultravioletti, è impermeabile e inalterabile. Queste sue caratteristiche lo rendono idoneo per tutti gli ambienti, specialmente umidi, stando tranquillamente a contatto con l'acqua, piuttosto che utilizzato come materiale alternativo per il calpestio. Realizzato in Italia, dalla collaborazione tra Inkiostro Bianco e Mapei, risponde appieno alle normative europee per la salute e la tutela dell'ambiente. Non contiene formaldeide ed è completamente inodore. È lavabile con acqua e i normali detergenti per la pulizia.

CARATTERISTICHE DISTINTIVE

- Non contiene formaldeide
- Elevata stabilità dimensionale
- Non arrugginisce
- Non ingiallisce
- Inodore

RESISTENZA

- Alla trazione
- All'abrasione
- Inalterabile e resistente alle aggressioni chimiche del cemento

AGENTI ATMOSFERICI

- Resistente agli agenti atmosferici
- Resistente ai raggi UV

FIREPROOF

- Ignifugo
- Classificazione di resistenza al fuoco: **B-s1, d0**

APPLICAZIONE

- Facile da tagliare e adattare alla conformazione del supporto
- Rapida applicazione
- Applicabile su superfici preesistenti
- Leggera e maneggevole

PULIZIA

- Lavabile con acqua e normali detergenti per la pulizia della casa

EN The Skerglass variant in EQ•dekor® fiber glass is made of a bidirectional special fabric, made of fiber glass treated with an alkali-resistant polyurethane substance. The result is a structurally advanced composite material, whose components create a material with superior physical, chemical and mechanical features, and excellent results in terms of decor. Light and easy to handle, the EQ•dekor® fiber glass material adapts with great flexibility to the shape of its support; for this reason it can be applied to walls and furniture with great simplicity. Lightweight and easy to handle, Skerglass fiber glass material is extremely versatile and can easily fit to the shape of its support; for this reason it can be applied to walls or furnishing units with great ease. Particularly stable, resistant to traction, abrasions, weathering and ultraviolet rays, it is waterproof and unalterable. Highly flexible, it is ideal for all environments and especially damp ones, even when in contact with water, and for its use as an alternative material for floor coverings. Made in Italy, from the cooperation between Inkiostro Bianco and Mapei, it fully meets European health, safety and environmental protection regulations. It does not contain formaldehyde and is completely odourless. It can be cleaned with water and standard cleaning products.

DISTINCTIVE FEATURES

- Does not contain formaldehyde
- High dimensional stability
- Does not rust
- Does not turn yellow
- Odourless

RESISTANCE

- To traction
- To abrasion
- Unalterable and resistant to chemical concrete degradation

WEATHER RESISTANCE

- Weather-resistant
- UV-resistant

FIREPROOF

- Fireproof
- Fire resistance rating: **B-s1, d0**

APPLICATION

- Easy to cut and fit on the support
- Quick application
- Applicable on pre-existing surfaces
- Lightweight and easy to handle

CLEANING

- Washable with water and ordinary house cleaning products

FR Dans la variante EQ•dekor® « fibre de verre », Skerglass est réalisé en tissu spécial bidirectionnel, constitué de fibre de verre traitée en surface avec une substance à base polyuréthane résistante aux alcalis. Il en résulte un matériau composite structurellement avancé, dont les composants s'intègrent en donnant un matériau offrant de meilleures caractéristiques du point de vue physique, chimique et mécanique, avec un rendement esthétique excellent. Léger et maniable, le matériau en EQ•dekor® fibre de verre s'adapte avec une grande souplesse à la configuration de son support ; raison pour laquelle il peut être appliqué de manière très simple sur des murs et des meubles. Particulièrement stable, résistant à la traction, à l'abrasion, aux agents atmosphériques et aux rayons UV, il est imperméable et inaltérable. Ces caractéristiques en font un produit adapté à tous les milieux, surtout humides, en restant tranquillement au contact de l'eau, ou à des utilisations comme matériau alternatif pour les surfaces de piétement. Réalisé en Italie, de la collaboration entre Inkiostro Bianco e Mapei, il répond pleinement aux normes européennes de santé et de protection de l'environnement. Il ne contient pas de formaldéhyde et est totalement sans odeur. Il est lavable à l'eau et avec des détergents normaux de nettoyage.

CARACTÉRISTIQUES DISTINCTIVES

- Sans formaldéhyde
- Grande stabilité dimensionnelle
- Ne rouille pas
- Ne jaunit pas
- Sans odeur

RÉSISTANCE

- À la traction
- À l'abrasion
- Inaltérable et résistant aux agressions chimiques du ciment

AGENTS ATMOSPHÉRIQUES

- Résistant aux agents atmosphériques.
- Résistant aux UV

FIREPROFF

- Ignifuge
- Classement au feu: **B-s1, d0**

APPLICATION

- Facile à couper et à adapter à la configuration du support
- Rapide à appliquer
- Applicable sur des surfaces préexistantes
- Produit léger et maniable

NETTOYAGE

- Lavable à l'eau et à l'aide de détergents normaux de nettoyage de la maison

Skerglass carta da parati vinilica/Skerglass vinyl wallpaper/ Papier peint vinyle Skerglass

IT Skerglass nella variante vinilica è formata da due strati: un lato superiore in vinile, stampabile e sul retro un foglio di TNT (tessuto non tessuto) che ne conferisce elevata stabilità dimensionale durante le fasi di applicazione e asciugatura, oltre che estrema facilità di montaggio e di eventuale rimozione.

CARATTERISTICHE DISTINTIVE

- Non contiene formaldeide
- Inassorbente
- Inodore

AGENTI ATMOSFERICI

- Resistente ai raggi UV

FIREPROOF

- Ignifugo
- Classificazione di resistenza al fuoco: **B-s2, d0**

APPLICAZIONE

- Facilità di montaggio
- Facilità di rimozione del prodotto
- Elevata stabilità dimensionale durante le fasi di applicazione e asciugatura del prodotto

PULIZIA

- Lavabile con acqua e sapone neutro

EN Skerglass in the vinyl variant consists of two layers: a printable vinyl upper side and a TNT (non-woven fabric) sheet on the back guaranteeing high dimensional stability during application and drying phases, as well as extremely easy assembly and potential removal.

DISTINCTIVE FEATURES

- Formaldehyde free
- Waterproof
- Odourless

WEATHER RESISTANCE

- Resistant to UV rays

FIREPROOF

- Fire resistantant
- Fire resistance classification: **B-s2, d0**

APPLICATION

- Easy to hang
- Easy to remove
- High dimensional stability during the application and drying stages

CLEANING

- Washable with water and neutral soap

FR Dans la variante « vinyle », Skerglass est formée de deux couches : un côté supérieur en vinyle, imprimable, avec, derrière, une feuille en TNT (tissu non tissé) qui donne une grande stabilité dimensionnelle pendant les phases d'application et de séchage, ainsi qu'une extrême facilité de montage et d'enlèvement.

CARACTÉRISTIQUES DISTINCTIVES

- Ne contient pas de formaldéhyde
- Ne contient pas de formaldéhyde
- Inodore

AGENTS ATMOSPHÉRIQUES

- Résistant aux rayons UV

FIREPROOF

- Ignifuge
- Classement au feu: **B-s2, d0**

APPLICATION

- Assemblage facile
- Retrait facile du produit
- Haute stabilité dimensionnelle dans les phases d'application et séchage

NETTOYAGE

- Lavable à l'eau et aux savon neutre

CERTIFICAZIONI E PARTNER FIBRA DI VETRO EQ•DEKOR®/CERTIFICATIONS AND PARTNER EQ•DEKOR® FIBER GLASS/ CERTIFICATIONS ET PARTENAIRES FIBRE DE VERRE EQ•DEKOR®



- IMO 2010 FTP Code Part 5
- ISO 1716: 2010

- Prodotto concesso da MAPEI a Inkiostro Bianco in esclusiva mondiale per uso decorativo.
- Product licenced to Inkiostro Bianco by MAPEI, worldwide licence for decorative use.
- Produit concédé en exclusivité mondiale par MAPEI à Inkiostro Bianco pour usage décoratif.

Inkiostro Bianco®
CREATIVE THINKING

Skिंगlass su parete/Wall mounted Skिंगlass/Application murale Skिंगlass

IT Entrambi i prodotti, fibra di vetro e vinile, vengono forniti con apposito collante Mapei per la posa e relative istruzioni di montaggio. La preparazione della superficie e la posa devono essere effettuata da personale specializzato: pareti, pavimenti o soffitti devono essere perfettamente lisci, piani, asciutti ed in tinta unita. **Per la fibra di vetro il fondo deve sempre essere in tinta grigio medio per esaltare maggiormente brillantezza, colori e grafiche della stessa.**

EN Both the fiber glass and vinyl products come with special Mapei glue for application and assembly instructions. Surface preparation and application must be carried out by specialized staff. Walls, floors or ceilings must be perfectly smooth, flat, dry and in solid colours. **The surface where fiber glass is applied should always be in a medium gray shade in order to enhance the patterns, colour and shine of the fiber glass.**

FR Les deux produits, fibre de verre et vinyle, sont fournis avec une colle Mapei spéciale pour la pose et avec les instructions de montage. La préparation de la surface et la pose doivent être confiées à un personnel spécialisé ; les murs, sols ou plafonds doivent être parfaitement lisses, plans, secs et en teinte unie. **Pour la fibre de verre, le fond doit toujours être de teinte gris moyen pour en rehausser le plus possible la brillante, les couleurs et les graphismes.**

Skिंगlass fibra di vetro EQ•dekor®

EQ•dekor® fiber glass Skिंगlass

Skिंगlass fibre de verre EQ•dekor®

Spessore: 0,47 ± 0,13 mm
Larghezza rotolo: 94 cm
Altezza rotolo: a richiesta

Thickness: 0,47 ± 0,13 mm
Roll width: 94 cm
Roll Height: on demand

Épaisseur : 0,47 ± 0,13 mm
Largeur du rouleau : 94 cm
Hauteur du rouleau : selon demande

PREZZO AL MQ (COMPRESIVO DI COLLANTE E FINITURA):
→ € 231,00

PRICE PER SQ.M (INCLUDING OF BONDING AGENT AND FINISH):
→ € 231,00

PRIX AU MC (COLLE ET FINITION INCLUSES) :
→ € 231,00

Skिंगlass carta da parati vinilica

Skिंगlass vynil wallpaper

Papier peint vinyle Skिंगlass

Spessore: 0,58 mm
Larghezza rotolo: 68 cm
Altezza rotolo: a richiesta

Thickness: 0,58 mm
Roll width: 68 cm
Roll Height: a richiesta

Épaisseur : 0,58 mm
Largeur du rouleau : 68 cm
Hauteur du rouleau : selon demande

PREZZO MQ (COMPRESIVO DI COLLANTE E FINITURA):
→ € 121,00

PRICE PER SQ.M (INCLUDING OF BONDING AGENT AND FINISH):
→ € 121,00

PRIX AU MC (COLLE ET FINITION INCLUSES) :
→ € 121,00

Calcolo dei Mq necessari/Estimate of the necessary sq.m/Calcul des quantités

Il calcolo viene effettuato considerando un'abbondanza pari a 10 cm in altezza per eventuali irregolarità della parete.

The calculation is made considering an abundance equal to 10 cm in height, for any irregularity of the wall.

Le calcul est fait en considérant une abondance égale à 10 cm en hauteur, pour toute irrégularité du mur.

Skिंगlass fibra di vetro EQ•dekor®/EQ•dekor® fiber glass Skिंगlass/Skिंगlass fibre de verre EQ•dekor®

Esempio per parete/Esempio per parete/Esempio per parete/L 3 x H 2,7 m

3,76 L rotoli necessari/W necessary rolls/L rouleaux nécessaires

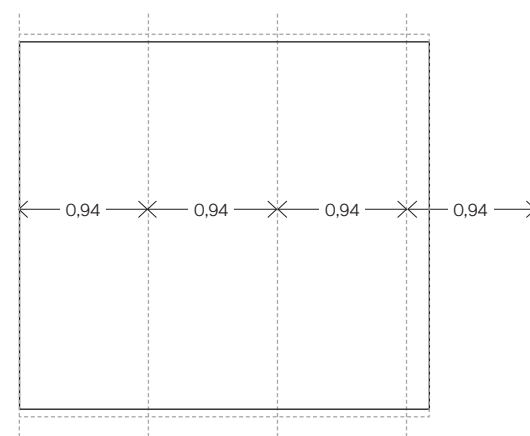

3 : 0,94 = 3,19 → N.4 rotoli (arrotondamento/rounding/arrondissement)
4 rotoli (0,94 x 4) x 2,80 = 10,53 mq (da acquistare/to purchase/à acheter)

Skिंगlass carta da parati vinilica/Skिंगlass vynil wallpaper/Papier peint vinyle Skिंगlass

Esempio per parete/Esempio per parete/Esempio per parete/L 3 x H 2,7 m

3,4 L rotoli necessari/W necessary rolls/L rouleaux nécessaires

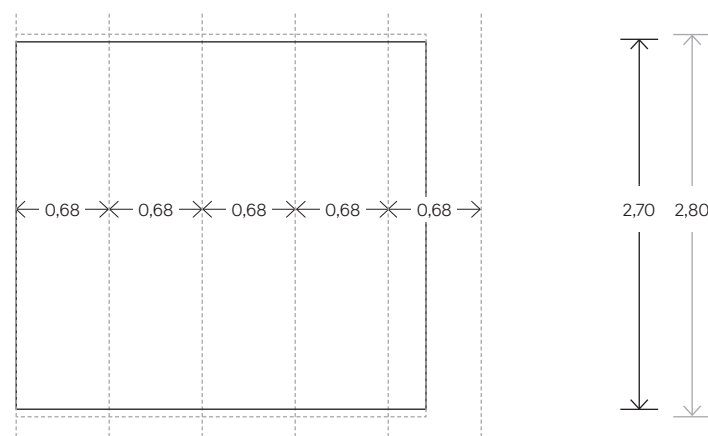

3 : 0,68 = 4,41 → N.5 rotoli (arrotondamento/rounding/arrondissement)
5 rotoli (0,68 x 5) x 2,80 = 9,52 mq (da acquistare/to purchase/à acheter)

Skिंगlass su frontali DES/Skिंगlass DES fronts/Skिंगlass DES façades

IT Le proposte grafiche rappresentate diventano un elemento fortemente caratterizzante e decorativo anche come nuovo materiale da inserire nel frontale della collezione DES. Il disegno scelto viene ridimensionato e definito direttamente dall'ufficio tecnico di Cerasa e sottoposto per approvazione al cliente. È possibile scegliere di decorare l'intera composizione o parte della stessa; qualora il soggetto scelto sia richiesto come decoro sia a parete che sul mobile, è necessario conoscere la precisa posizione della composizione bagno rispetto alla parete da rivestire.

EN The decorative patterns become a highly characterizing element also as a new material for the DES collection cabinet fronts. The selected design is resized and finalized directly by Cerasa's technical office and submitted to our customers for approval. The approved design can be applied on the furnishing unit or on both the unit and the wall, depending on customers' requirements. If the decoration is also requested for the wall and the unit, we take into consideration the precise position of the bathroom unit with respect to the wall to be covered.

FR Les propositions graphiques représentées deviennent un élément fortement caractérisant et décoratif, même comme nouveau matériau à insérer dans la porte de la collection DES. Le dessin choisi est redimensionné et défini directement par le bureau technique de Cerasa, puis il est soumis au client pour approbation. On peut choisir de décorer l'entière composition ou une partie seulement ; si le motif choisi est demandé comme décoration murale et sur le meuble, il faut connaître la position précise de la composition de la salle de bains par rapport au mur à revêtir.

Per la quotazione del mobile DES con frontali in fibra di vetro EQ•dekor® o carta da parati vinilica fare riferimento al listino della collezione stessa prendendo come riferimento le categorie di prezzo indicate in calce.

For a price estimate of DES cabinet with EQ•dekor® fiber glass or vinyl wallpaper fronts please refer to the collection price list, taking as a reference the price categories indicated below.

Pour le prix du meuble DES avec des façades en fibre de verre EQ•dekor® ou en papier peint vinyle, voir le tarif de cette même collection, en prenant comme référence les catégories de prix indiquées en bas de page.



PER FRONTALI IN FIBRA DI VETRO
→ CATEGORIA DI PREZZO DES
IA (PRECOMPOSTO)

FOR FIBER GLASS FRONTS
→ DES CATEGORY
IA (COMPOSED VENEER)

PRIX DES FAÇADES EN FIBRE DE VETRE
→ CATÉGORIE DES PRIX
IA (PLACAGE COMPOSÉ)

PER FRONTALI IN CARTA VINILICA
→ CATEGORIA DI PREZZO DES
I7 (MATERICO 3D)

FOR VINYL PAPER FRONTS
→ DES CATEGORY
I7 (MATERICO 3D)

PRIX DES FAÇADES EN VINYLE
→ CATÉGORIE DES PRIX
I7 (MATERICO 3D)

—→ Una nuova collezione di basi lavabo a terra con piedini regolabili rientranti, realizzate con cassetto sotto lavabo, cassettone contenitivo e anta destra o sinistra a richiesta. Single è un modello dalla linea pulita ed essenziale, dall'importante capacità contenitiva e dall'estetica accattivante definita dall'assenza della maniglia. In abbinamento la consolle lavabo Unica, ora implementata anche dal pratico vassoio; in alternativa è possibile inserire diverse tipologie di lavabo da appoggio. Single è disponibile con configurazioni prestabilite in n.6 larghezze: 60/70/85/95/105/120 cm, profondità 45,5 cm, e in tutte le finiture nobilitate, con l'aggiunta di 4 novità: **Dogato Wood, Dogato Color, Pietra e Coast.**

EN A new collection of bathroom units with retractable and adjustable feet, featuring a drawer under the washbasin, and a cupboard with right or left opening door as required. Single is a model with clean and essential lines, plenty of storage space and an attractive aesthetic, defined by the absence of visible handles. It can be combined with the Unica washbasin console, now provided with the practical tray, or with different types of countertop washbasin. Single is available with pre-arranged configurations in six width sizes: 60/70/85/95/105/120 cm, 45,5 cm depth, and in all finishes, including the new additional melamine finishes **Dogato Wood, Dogato Color, Pietra and Coast.**

FR Nouvelle collection d'éléments sous-vasque au sol à pieds réglables rentrants, réalisées avec un tiroir sous le lavabo, un grand tiroir de rangement et une porte droite ou gauche sur demande. Single est un modèle à la ligne épurée et essentielle, d'une grande capacité de rangement et d'une esthétique attrayante grâce à l'absence de la poignée. En association, le plan-vasque Unica, désormais complétée aussi par une tablette pratique ; en alternative, on peut insérer différents types de lavabos à poser. Single est disponible avec des configurations préétablies en six largeurs : 60/70/85/95/105/120 cm, profondeur 45,5 cm, et dans toutes les finitions surfacées, avec l'ajout de 4 nouveautés : **Dogato Wood, Dogato Color, Pietra et Coast.**

SINGLE

FLEXIBLE
HUB

CO CERASA®

IT Alla base lavabo Single è possibile abbinare a proprio piacimento gli innumerevoli specchi, luci e complementi presenti nelle collezioni Cerasa.

EN The Single washbasin unit can be combined with a wide range of mirrors, lighting options and complements available in the Cerasa collections.

FR L'élément sous-vasque Single peut être associé, comme on le souhaite, aux innombrables lumières, miroirs et compléments présents dans les collections Cerasa.





IT La base lavabo Single esprime tutto il suo carattere utilizzata anche con lavabi in appoggio. La scelta dei piani (P 45,8 cm) e dei lavabi, con la relativa quotazione, è consultabile nei listini delle collezioni Cerasa.

EN The Single washbasin unit expresses all its character even when used with countertop basins. The choice of tops (45.8 cm depth) and basins and their pricing can be consulted in the price lists of the Cerasa collections.

FR L'élément sous-vasque Single exprime tout son caractère lorsqu'on l'utilise aussi avec des lavabos à poser. On peut consulter le choix des plans (P 45,8 cm) et des lavabos, avec le prix correspondant, dans les tarifs du les collections Cerasa.





IT La dimensione dell'anta varia a seconda della larghezza totale della base Single:
L 20 cm per basi L 60 e 70 cm
L 25 cm per basi L 85 e 95 cm
L 35 cm per basi L 105 e 120 cm

EN Door size varies according to total width of Single washbasin unit:
W 20 cm for washbasin units W 60 and 70 cm
W 25 cm for washbasin units W 85 and 95 cm
W 35 cm for washbasin units W 105 and 120 cm

FR La mesure de la porte varie en fonction de la largeur totale de l'élément sous-vasque Single :
L 20 cm pour éléments sous-vasque L 60 et 70 cm
L 25 cm pour éléments sous-vasque L 85 et 95 cm
L 35 cm pour éléments sous-vasque L 105 et 120 cm

IT L'apertura dei frontali avviene grazie alla lavorazione inclinata del bordo su cui è applicato un profilo metallico in finitura Champagne.

EN Fronts are opened thanks to the inclined edge with integrated metal handle in Champagne finish.

FR Les façades s'ouvrent grâce au chant incliné avec poignée intégrée en métal, en finition Champagne.

**Base lavabo Single/Single washbasin unit/
Élément sous-vasque Single**

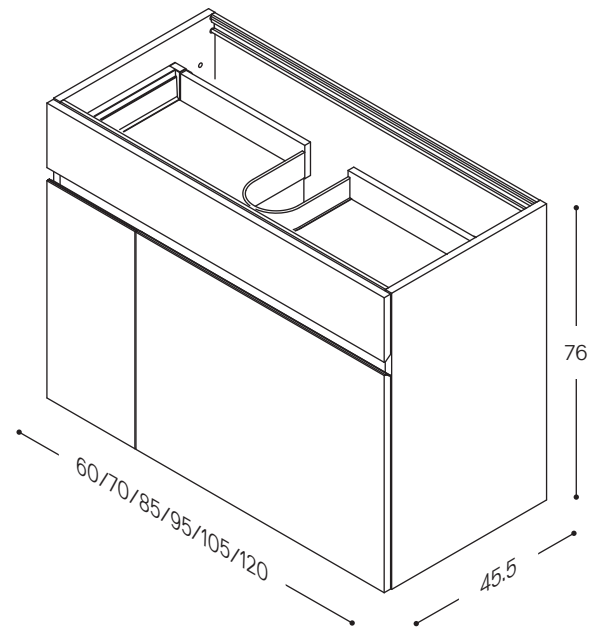

Disponibile Dx/Sx
Altezza base comprensiva di piedini H 2 cm regolabili
Available in the Right/Left versions
Base height including 2 cm adjustable feet
Disponibile Dr/Gh
Hauteur de la base avec pieds H 2 cm réglables

L 60 cm S1L74 872 60 P1 → € 686,00 Kg 36,62 Vol 0,23	L 70 cm S1L74 872 70 P1 → € 699,00 Kg 39,57 Vol 0,27	L 85 cm S1L74 872 85 P1 → € 732,00 Kg 43,49 Vol 0,33
L 95 cm S1L74 872 95 P1 → € 750,00 Kg 46,67 Vol 0,37	L 105 cm S1L74 872 A5 P1 → € 765,00 Kg 49,13 Vol 0,41	L 120 cm S1L74 872 C0 P1 → € 794,00 Kg 53,71 Vol 0,46

Vassoio/Tray/Tablette

Solid Surface Bianco opaco
Matt Bianco Solid Surface
Solid Surface Bianco mat

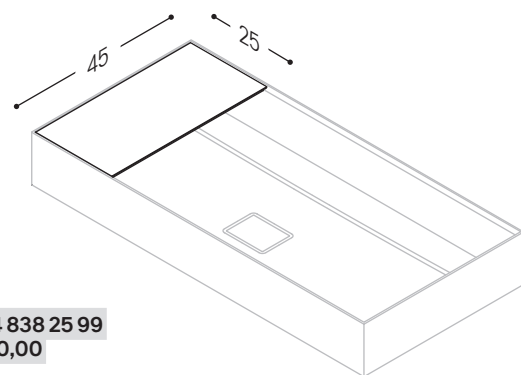

ZC A04 838 25 99
→ € 160,00
Kg 2,55
Vol 0,002

**Consolle Unica/Unica integral basin/
Plan-vasque Unica**

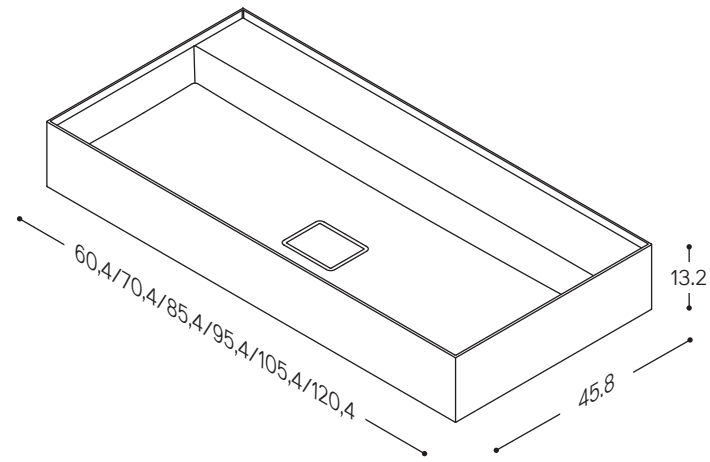

Solid Surface Bianco opaco
Matt Bianco Solid Surface
Solid Surface Bianco mat

L 60,4 cm ZC ALC N60 17 99 → € 448,00 Kg 15,2 Vol 0,04	L 70,4 cm ZC ALC N70 17 99 → € 509,00 Kg 17,25 Vol 0,05	L 85,4 cm ZC ALC N85 17 99 → € 570,00 Kg 19,3 Vol 0,06
L 95,4 cm ZC ALC N95 17 99 → € 635,00 Kg 21,4 Vol 0,07	L 105,4 cm ZC ALC NA5 17 99 → € 710,00 Kg 25,45 Vol 0,08	L 120,4 cm ZC ALC NC0 17 99 → € 771,00 Kg 27,5 Vol 0,09

**Piani e lavabi da appoggio/Tops and standing basins/
Plans de toilette et vasques**

Per la scelta e la quotazione di piani e lavabi, fare riferimento ai listini delle collezioni Cerasa/For the choice of tops and basins and their pricing please refer to the price lists of the Cerasa collections/
Pour le choix et le prix des plans et des lavabos, voir les tarifs des collections Cerasa

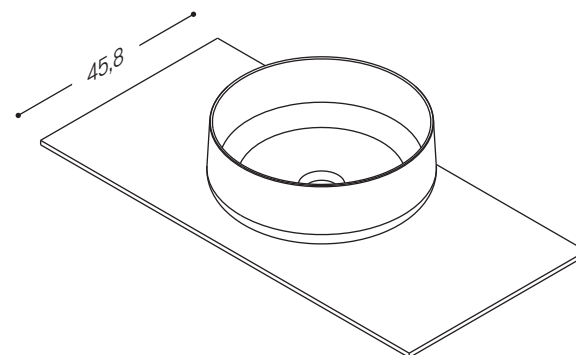

Nuovi nobilitati/New laminates/Nouveaux stratifiés



Coast



Dogato Color

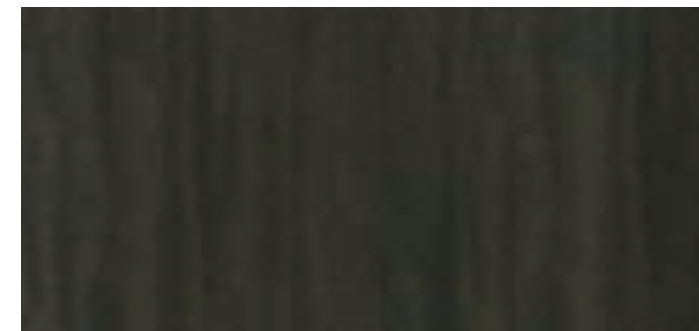

Dogato Wood



Pietra

DISPONIBILI ANCHE PER LE COLLEZIONI
CARTABIANCA, SEGNO, MISURA
E REGOLA.

ALSO AVAILABLE FOR THE CARTABIANCA,
SEGNO, MISURA AND REGOLA
COLLECTIONS.

DISPONIBLES ÉGALEMENT POUR LES
COLLECTIONS CARTABIANCA, SEGNO,
MISURA ET REGOLA.

Nobilitati/Laminates/Stratifiés

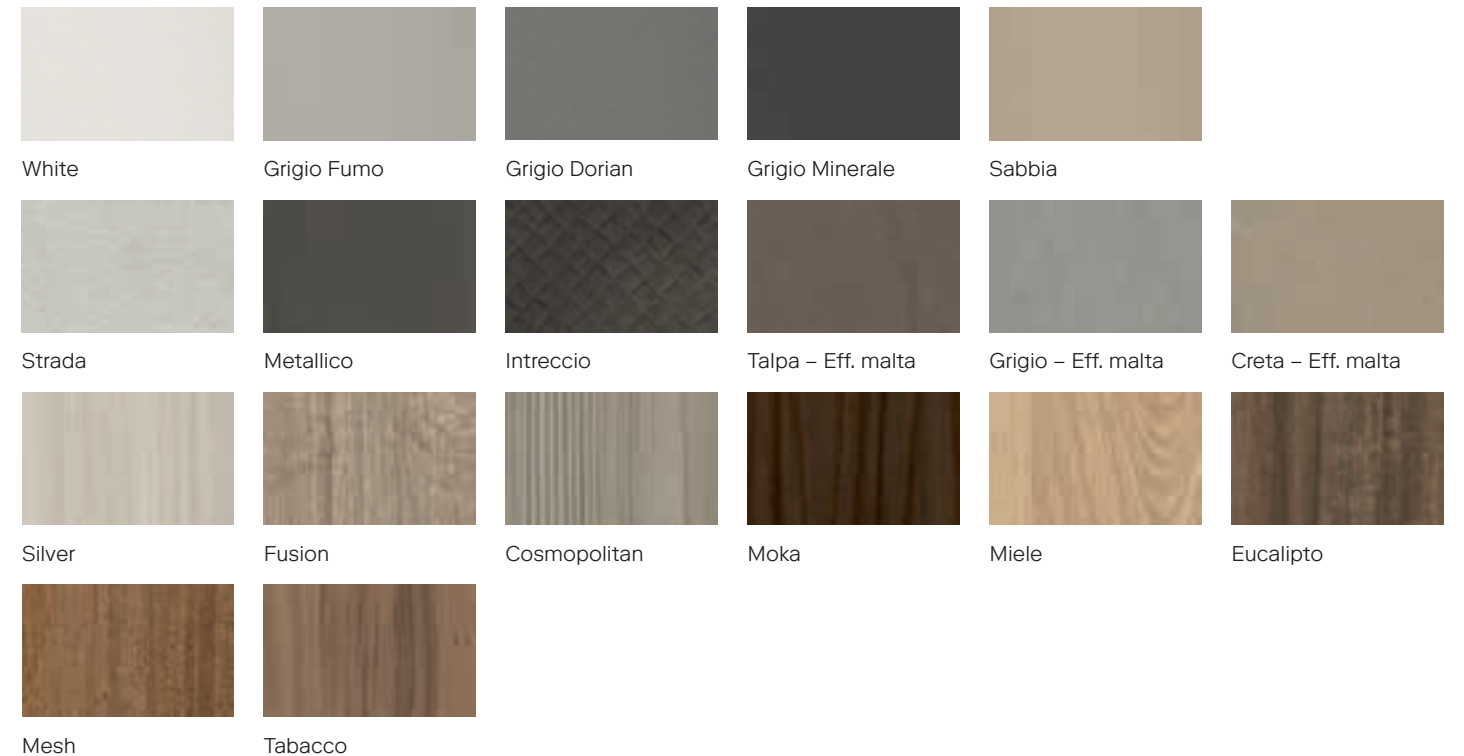

—→ L'utilizzo di Skinglass in fibra di vetro EQ•dekor® trova la sua espressione anche come materiale di rivestimento per i lavabi monoliti Cerasa Colonna e Totem. I lavabi vengono forniti già rivestiti e completi di un apposito elemento in metallo, posto sul bordo superiore del lavabo, in finitura bianco opaco. I lavabi Colonna e Totem, realizzati in Solid Surface bianco opaco, vivono e si inseriscono nella sala da bagno sia con il loro materiale originale, sia arricchiti da colorazioni esterne ed ora anche in questa nuova particolare veste con fibra di vetro.

EN Skinglass EQ•dekor® fiber glass is also an excellent material for Cerasa's freestanding washbasins Colonna and Totem. They come already coated and completed with a special metal element, placed on the top edge of the washbasin, in a matte white finish. The Colonna and Totem washbasins, made in the white matte solid surface, will enhance the décor of your bathroom both in the versions with their original material or coated, and also with this new Skinglass fiber glass version.

FR Skinglass en fibre de verre EQ•dekor® peut également être utilisé comme matériau de revêtement pour les lavabos monolithes Cerasa Colonna et Totem. Les lavabos sont fournis déjà complets et revêtus d'un élément en métal spécifique, placé dans le bord supérieur du lavabo, en finition blanc opaque. Les lavabos Colonna et Totem, réalisés en solid surface blanc opaque, prennent place dans la salle de bains soit avec leur matériau d'origine, soit agrémentés de couleurs extérieures et désormais dans cette nouvelle présentation particulière avec Skinglass fibre de verre.

FREESTANDING

THE SCULPTURE
EFFECT

CO CERASA®



IT Colonna è disponibile in due versioni: con alloggiamento miscelatore, o senza per utilizzo di rubinetteria a parete.

EN Colonna is available in two versions: with a mixer tap hole or without, for use with wall mounted taps.

FR Colonna est disponible en deux versions : avec ou sans logement du mitigeur pour utilisation d'une robinetterie murale.

COLONNA

LAVABO/BASIN/VASQUE





TOTEM

LAVABO/BASIN/VASQUE

IT Linee squadrate ed eleganti per Totem, anch'esso posizionabile a parete o centro stanza e accessoriabile con pratiche mensole contenitive realizzabili in più finiture della linea Sistema.

EN With its square, elegant lines, Totem can be placed against the wall or in the middle of the room and accessorized with practical storage shelves in the multiple finishes of the Sistema line.

FR Avec ses lignes droites et élégantes, Totem peut lui aussi être placé contre le mur ou au centre de la pièce et être équipé d'étagères de rangement pratiques, réalisables en plusieurs finitions de la ligne Sistema.

↓ Collection
NEROLAB
FRAME





IT L'elemento in metallo sul bordo superiore, in finitura bianco opaco, è un dettaglio che arricchisce completa e protegge entrambi i lavabi.

EN The metal element on the upper edge in the matt white finish embellishes, completes and protects both basins.

FR L'élément en métal sur le bord supérieur, en finition blanc opaque, est un détail qui agrément, complète et protège les deux lavabos.



Solid surface **99**
Solid surface **99**
Solid surface **99**

Laccato esterno opaco **P5**
Matt lacquered exterior **P5**
Laqué extérieur opaque **P5**

Skerglass fibra di vetro **F1***
Skerglass Fiber glass **F1***
Fibre de verre Skerglass **F1***

COLONNA

→ € 1370,00

→ € 1588,00

→ € 2406,00

Cod
ZCALPR44 01
Kg 51,00
Vol 0,36

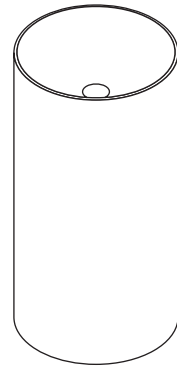
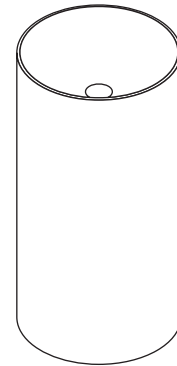
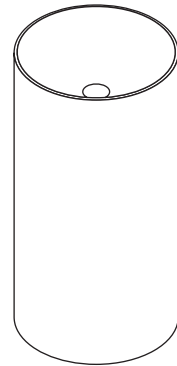
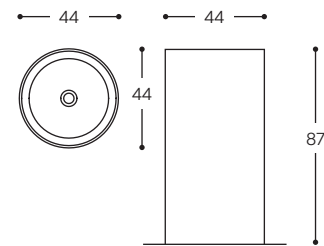

COLONNA 2

→ € 1410,00

→ € 1629,00

→ € 2445,00

Cod
ZCALPR44 02
Kg 51,00
Vol 0,36

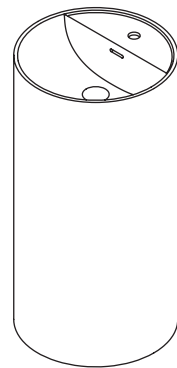
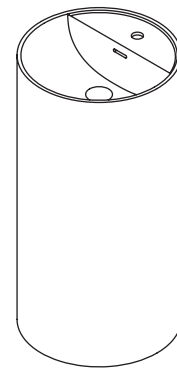
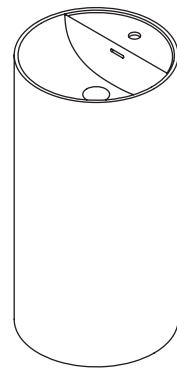
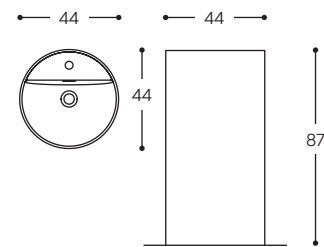

TOTEM

→ € 1794,00

→ € 2109,00

→ € 2968,00

Cod
ZCALPR44 03
Kg 51,00
Vol 0,36

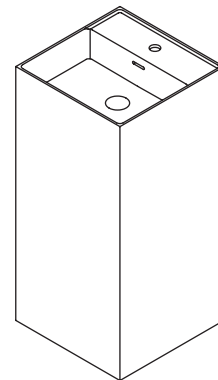
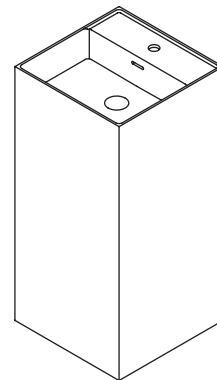
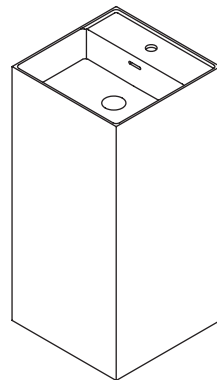
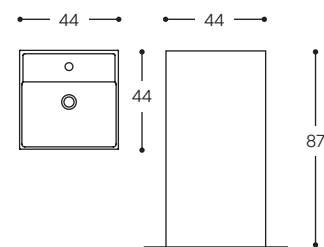

PREDISPOSIZIONE SCARICHI A PARETE
ARRANGEMENT FOR WALL WATER DRAIN
PRÉDISPOSITION POUR ÉVACUATION DE L'EAU AU MUR

Cod
ZC WLV SCP 0199
→ € 38,00

* I prezzi sono riferiti all'articolo già rivestito con fibra di vetro EQ•dekor® Skerglass ed elemento in metallo di finitura EQ•dekor® fiber glass and finishing material element
* The prices refer to the item already coated with Skerglass EQ•dekor® fiber glass and finishing material element
* Les prix se rapportent à l'article déjà revêtu de EQ•dekor® fibre de verre Skerglass et de l'élément en métal de finition

Mensola per lavabo Colonna/ Shelf for Colonna basin/Étagère pour vasque Colonna

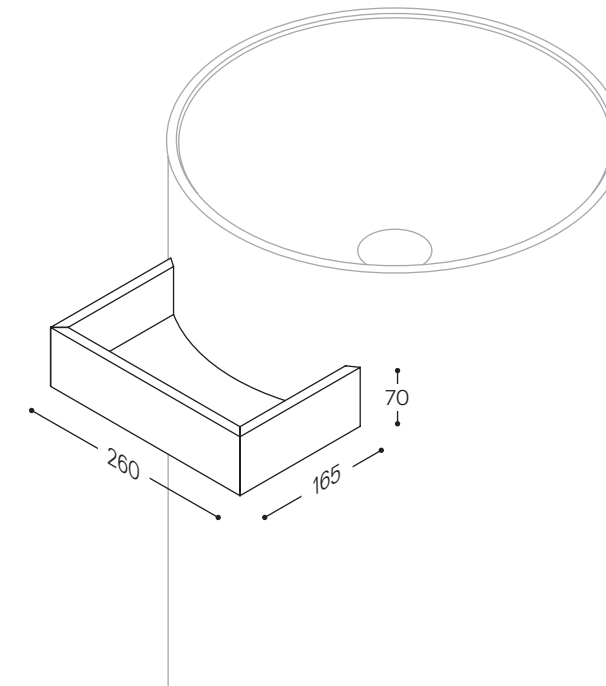

Per la scelta delle finiture fare riferimento al programma Sistema
For the choice of finishes, please consult the Sistema programme
Pour choisir les finitions, reportez-vous au programme Sistema

Cod
M02 755 17*
Kg 0,003
Vol 1,96

Cat. P1
Nobilitati/Laminates/Stratifié
→ € 240,00

Cat. P3
Laccato Bianco opaco/Matt Bianco lacquered/Laqué Bianco mat
→ € 282,00

Cat. P5
Laccato colore opaco/Matt colour lacquered/Laqué couleur mat
→ € 282,00

Cat. P7
Impiallacciato/Veneered/Plaqué
→ € 310,00

* Prefisso SS per finiture CartaBianca e Segno
Prefisso SN per finiture NeroLab
* SS prefix for finishes of CartaBianca and Segno collections
SN prefix for finishes of NeroLab collection
* Préfixe SS pour les finitions des collections CartaBianca et Segno
Préfixe SN pour les finitions de la collection NeroLab

Mensola per lavabo Totem/ Shelf for Totem basin/Étagère pour vasque Totem

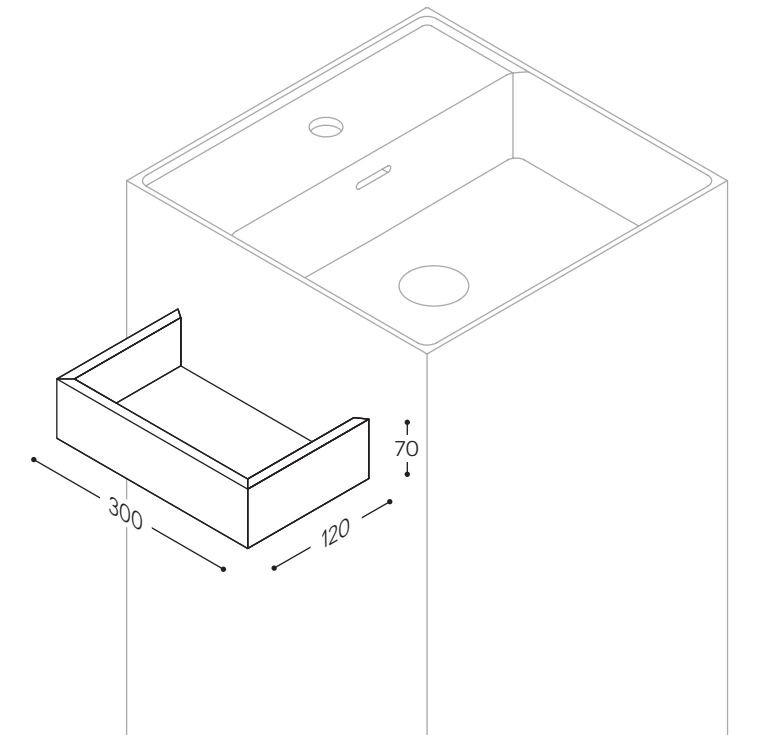

Per la scelta delle finiture fare riferimento al programma Sistema
For the choice of finishes, please consult the Sistema programme
Pour choisir les finitions, reportez-vous au programme Sistema

Cod
M03 755 12*
Kg 0,003
Vol 1,97

Cat. P1
Nobilitati/Laminates/Stratifié
→ € 218,00

Cat. P3
Laccato Bianco opaco/Matt Bianco lacquered/Laqué Bianco mat
→ € 257,00

Cat. P5
Laccato colore opaco/Matt colour lacquered/Laqué couleur mat
→ € 257,00

Cat. P7
Impiallacciato/Veneered/Plaqué
→ € 288,00



IT Entrambi i lavabi possono, essere proposti singolarmente o contestualizzati con le collezioni CartaBianca, Segno e NeroLab; gli stessi, affiancati alle basi e top di profondità 36 cm, creano combinazioni originali.

EN Both basins are either offered individually or within the collections CartaBianca, Segno and NeroLab; in combination with the base units and tops of 36 cm in depth, they create original configurations.

FR Les deux lavabos peuvent non seulement être proposés individuellement, mais aussi être mis en contexte dans les collections CartaBianca, Segno et NeroLab ; associés aux bases et aux plans de 36 cm de profondeur, ils créent des combinaisons et des situations inédites.

↑ Collection
NEROLAB/SEGNO
FRAME



IT Inserire i lavabi freestanding in composizione è molto semplice: basta definire la tipologia del lavabo e a questo affiancare le basi profonde 36 cm scelte tra i listini CartaBianca, Segno, o NeroLab. Alla composizione va aggiunto il piano top di profondità 36 cm definito tra i vari materiali disponibili nei relativi listini, prendendo in considerazione la fascia di prezzo tra 20 e 42 cm e sommando la maggiorazione per piano sagomato **W00 SAG 00** e quella per il miscelatore **W00 FRO 01**. Il mobile risulta montato 4 cm più in basso rispetto al bordo del lavabo. Tale posizione può essere modificata al momento dell'installazione in funzione dell'altezza del miscelatore.

EN Fitting the freestanding wash basins is very simple: just choose the type of basin and combine it with the 36 cm deep units included in the CartaBianca, Segno or NeroLab collections. The composition should be completed with the matching countertop (36 cm depth) in the materials available in the relevant lists, taking into account the price range corresponding to sizes between 20 and 42 cm, and adding the surcharge for the **W00 SAG 00** shaped countertop and the surcharge for the **W00 FRO 01** mixer. The cabinet is mounted 4 cm lower than the edge of the washbasin. The position can be changed at the time of installation also depending on the height of the mixer.

FR Mettre en place les lavabos autoportants dans une composition est très simple : il suffit de définir le type du lavabo et de lui associer les bases de 36 cm de profondeur choisies dans les tarifs CartaBianca, Segno ou NeroLab. On doit ajouter à la composition le plan de 36 cm de profondeur défini parmi les divers matériaux disponibles dans les tarifs correspondants, en prenant la tranche de prix entre 20 et 42 cm et en ajoutant la majoration pour le plan façonné **W00 SAG 00** et celle pour le mitigeur **W00 FRO 01**. Le meuble est monté 4 cm plus bas que le bord du lavabo. La position peut être modifiée lors de l'installation, également en fonction de la hauteur du mitigeur.

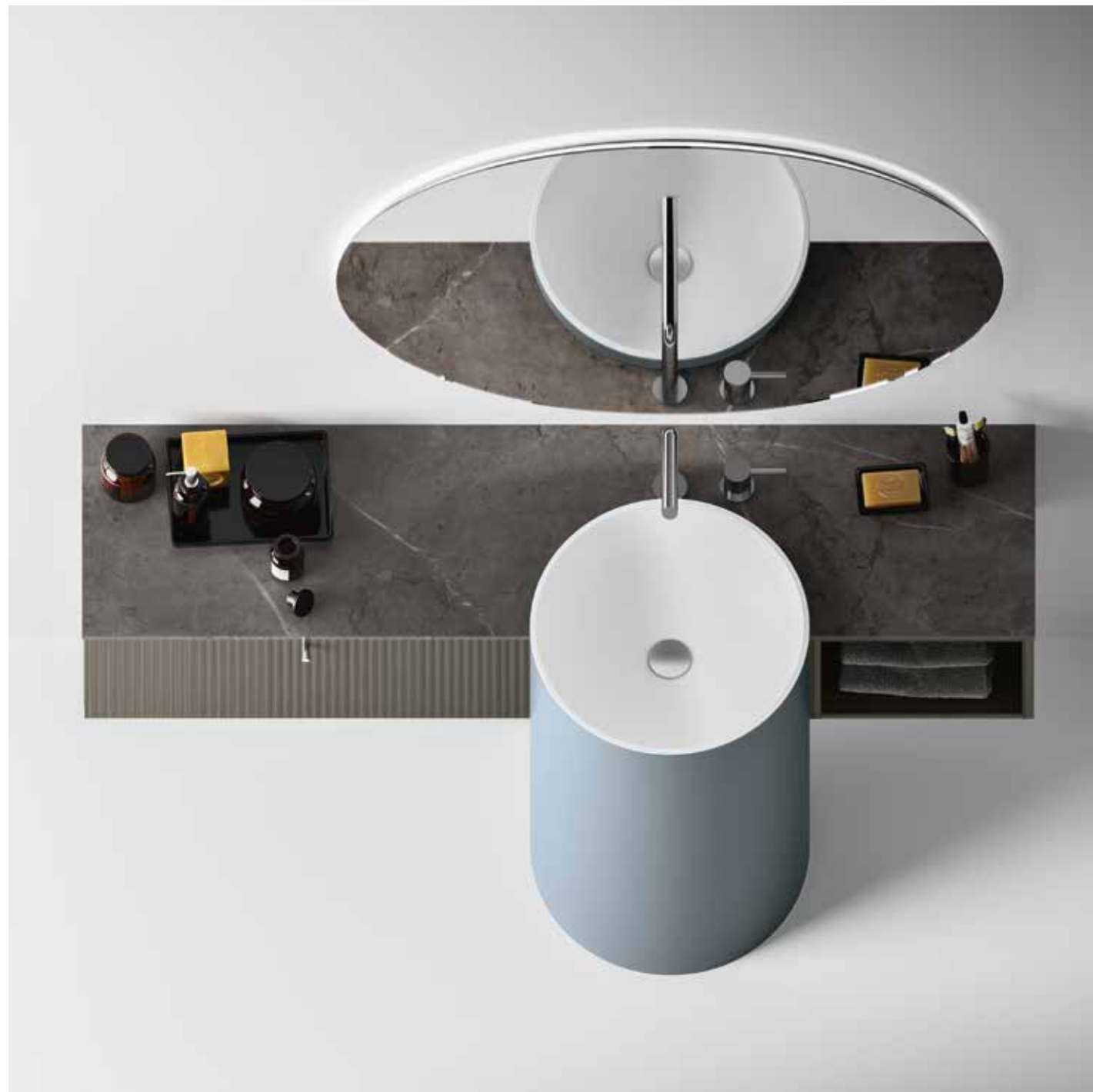

Esempio composizione lavabo Colonna centrale/ Example of Colonna basin central composition/ Exemple de composition vasque Colonna centrale



- B33 030 50 ①
- +
- ZCALP R44 01 ②
- +
- B33 060 35 ③
- +
- T42 DRT 00 ④
- +
- W00 SAG 00
Maggiorazione per sagoma top
Extra charge for top shaping
Supplément pour façonnage
du plan de toilette ⑤
- +
- W00 FRO 01
Maggiorazione singolo
foro per miscelatore
Extra charge for single
cut for mixer
Supplément pour découpe
unique pour mitigeur ⑥

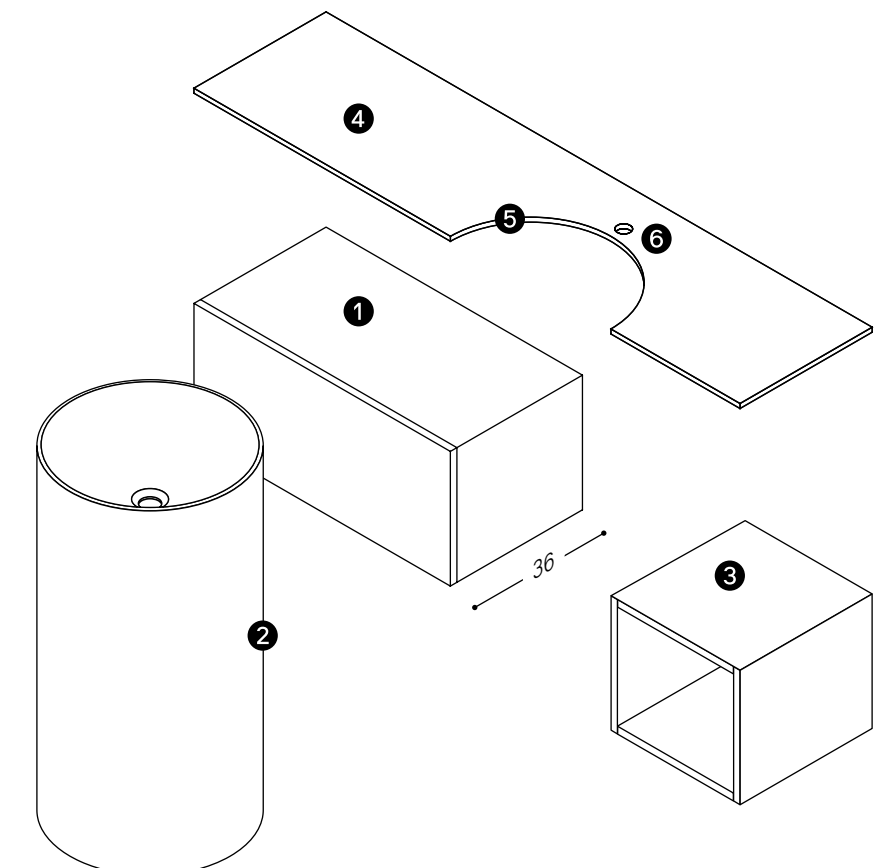

Esempio composizione lavabo Colonna terminale/Example of Colonna basin terminal configuration/Exemple de composition vasque Colonna terminale

- F32 873 00**
Fianco/Side/Côté **1**
- +
- ZC ALP R44 01** **2**
- +
- B33 060 35** **3**
- +
- T42 DRT 00** **4**
- +
- W00 SAG 00**
Maggiorazione per sagoma top
Extra charge for top shaping
Supplément pour façonnage
du plan de toilette **5**
- +
- W00 FRO 01**
Maggiorazione singolo
foro per miscelatore
Extra charge for single
cut for mixer
Supplément pour découpe
unique pour mitigeur **6**

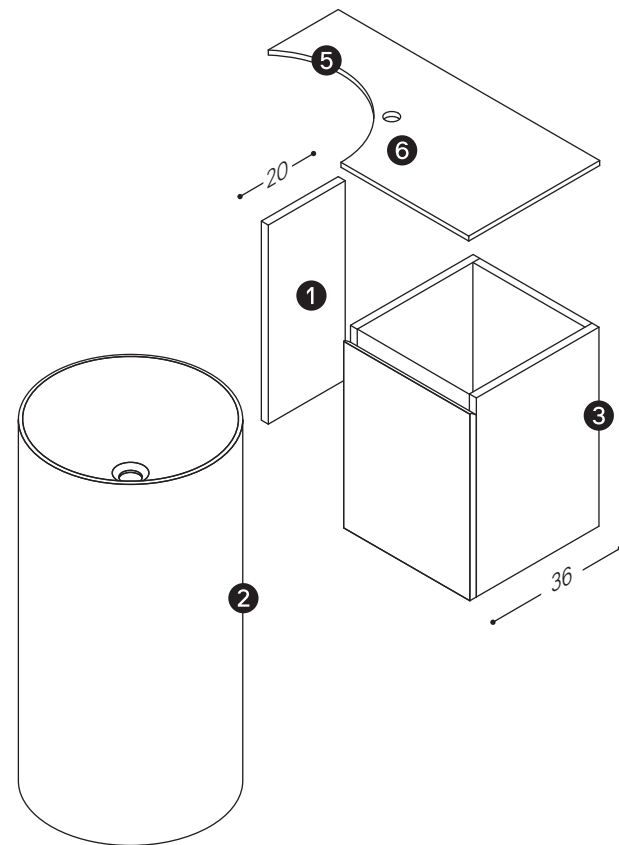

Fianchi/Sides/Côtés

Categorie/Categories/Catégories

	H 32 cm F32 873 00* Kg 0,92 Vol 0,001	H 48 cm F42 873 00* Kg 1,37 Vol 0,002	H 56 F52 873 00* Kg 1,60 Vol 0,003
P1 Nobilitati/Laminates/Stratifié	€ 121,00	€ 124,00	€ 127,00
P3 Laccato Bianco opaco/Matt Bianco lacquered/Laqué Bianco mat	€ 138,00	€ 149,00	€ 155,00
P4 Laccato Bianco lucido/Glossy Bianco lacquered/Laqué Bianco brillante	€ 145,00	€ 160,00	€ 165,00
P5 Laccato colore opaco/Matt colour lacquered/Laqué couleur mat	€ 142,00	€ 157,00	€ 163,00
P6 Laccato colore lucido/Glossy colour lacquered/Laqué couleur brillante	€ 147,00	€ 162,00	€ 169,00
P7 Impiallacciato/Veneered/Plaqué	€ 179,00	€ 185,00	€ 187,00

Tutti i fianchi hanno profondità 20 cm e spessore 1,8 cm e sono comprensivi delle staffe di supporto.

All sides are 20 cm deep and 1.8 cm thick and include support brackets.

Tous les côtés ont une profondeur de 20 cm et une épaisseur de 1,8 cm et sont munis des pattes de support.

* Prefisso SS per finiture CartaBianca e Segno
Prefisso SN per finiture NeroLab

* SS prefix for finishes of CartaBianca and Segno collections
SN prefix for finishes of NeroLab collection

* Préfixe SS pour les finitions des collections CartaBianca et Segno
Préfixe SN pour les finitions de la collection NeroLab

Esempio utilizzo lavabo Totem/Example of Totem basin configuration/Exemple d'utilisation du vasque Totem

IT Anche il lavabo Totem può essere posizionato in composizione, semplicemente affiancando elementi sospesi delle collezioni Sistema o mensoloni al cm, disponibili in molteplici materiali.

EN The Totem washbasin can also be positioned in a configuration, simply by placing on its sides suspended elements from the Sistema collections or customizable shelves, available in a wide range of materials.

FR Le lavabo totem peut lui aussi être placé dans une composition, en lui associant simplement des éléments suspendus appartenant aux collections Sistema ou des étagères au cm, disponibles en de multiples matériaux.

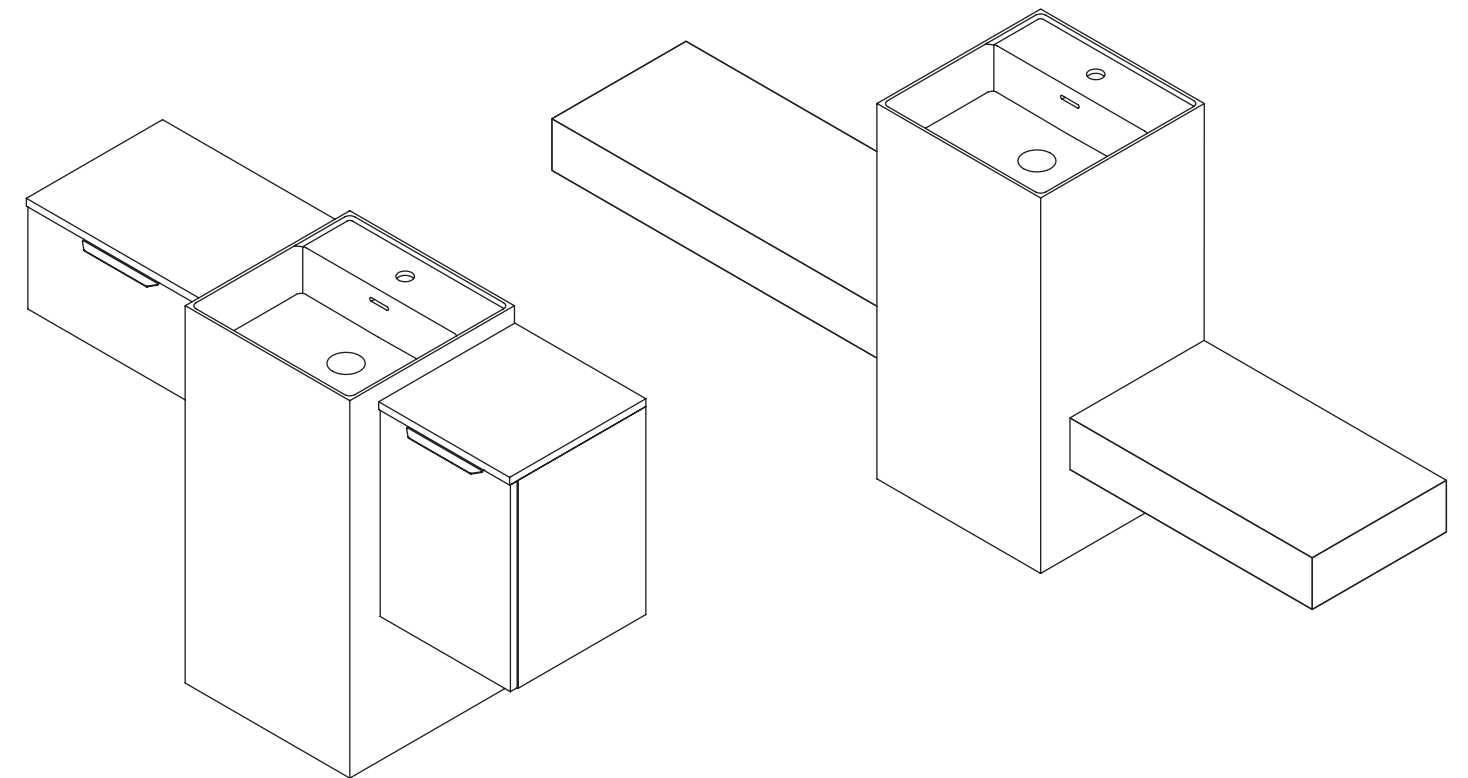

Impianto idrico/Plumbing system/Système d'eau

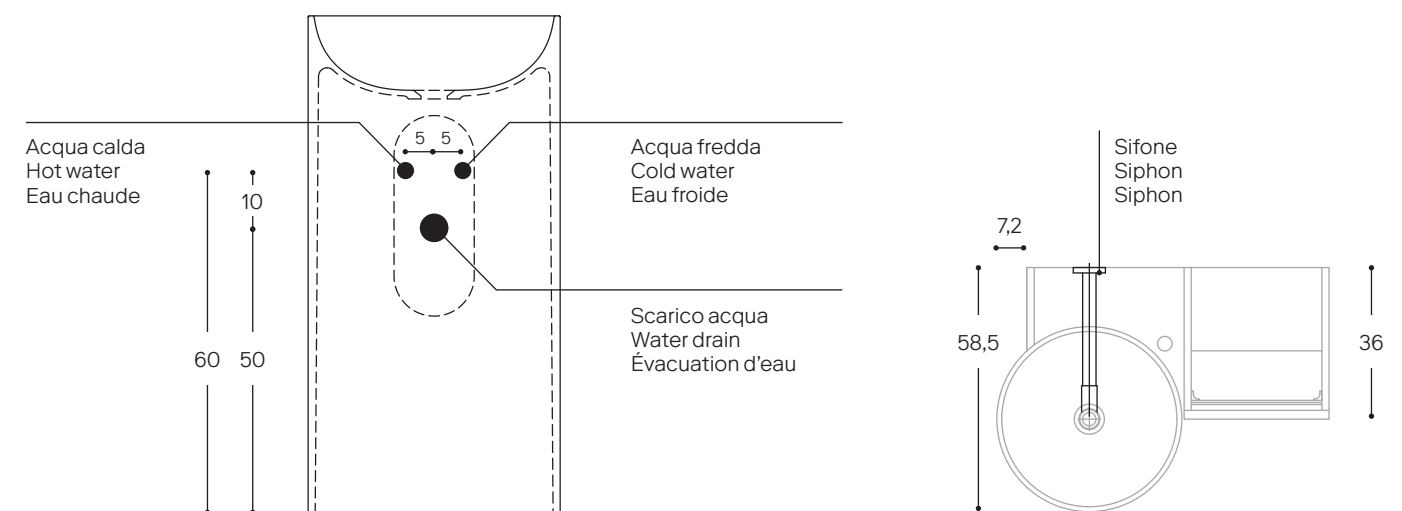

—→ A integrazione delle collezioni, Cerasa ha realizzato anche alcune nuove proposte in termini di complementi e arredi. Nuove misure per l'iconico specchio tondo illuminato che ne vanno a completare la gamma; una nuova colonna armadio per la collezione CartaBianca dotata di ante rientranti, ripiani in cristallo e pratico vassoio scorrevole; paravento e servomuto in tessuto coordinabile con tutte le nuove grafiche realizzate per Skinglass. Il total look diventa sempre più personalizzabile e flessibile, grazie anche alle vasche da bagno colorate.

EN Cerasa offers a range of additional accessories and furnishings to complement its collections. These include new sizes for the iconic illuminated round mirror, completing the range; a new cabinet unit for the CartaBianca collection with sliding doors, crystal shelves and a handy sliding tray; folding screen and towel rack in fabric that can be coordinated with all the new decorative patterns created for Skinglass. Your bathroom's total look becomes more and more customizable and flexible, also thanks to the colorful bathtubs.

FR Pour enrichir ses collections, Cerasa a également réalisé de nouvelles propositions en termes de compléments et d'ameublements. De nouvelles mesures pour l'iconique miroir rond éclairé qui viennent en compléter la gamme ; une nouvelle colonne armoire pour la collection CartaBianca, équipée de portes rentrantes, d'étagères en verre et d'un plateau coulissant pratique ; un paravent et un valet en tissu pouvant être coordonné avec tous les nouveaux graphismes réalisés pour Skinglass. Le total look devient de plus en plus personnalisable et flexible, grâce également aux baignoires colorées.

COMPLEMENTS

FLEXIBLE
TOTAL LOOK

CO CERASA®

SPECCHI

MIRRORS/MIROIRS



IT Tra le novità presenti in questo catalogo, ci sono gli specchi tondi illuminati, articoli di forte attualità e tendenza che Cerasa propone in 3 nuove dimensioni 70, 95 e 105 cm, oltre alla già esistente da 130 cm, che è possibile inserire in tutte le collezioni a catalogo.

EN Among the new offerings in this catalogue, we can find the illuminated round mirrors, highly fashionable furnishing elements that Cerasa proposes in three sizes, the new 70, 95 and 105 cm in addition to the currently available 130 cm model, and they can be included in all our present collections.

FR Les miroirs ronds éclairés figurent parmi les nouveautés présentes dans ce catalogue. Ce sont des articles très actuels et tendance, que Cerasa propose en trois nouvelles dimensions, 70, 95 et 105 cm outre les actuels 130 cm, et que l'on peut insérer dans toutes les collections du catalogue.

TONDO 2

L 70 cm
ZC S72 752 70 99
→ € 396,00
Kg 11,07
Vol 0,04

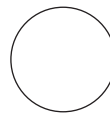

TONDO 2

L 95 cm
ZC S92 752 95 99
→ € 463,00
Kg 15,00
Vol 0,06

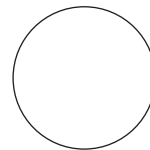

TONDO 2

L 105 cm
ZC SA2 752 A5 99
→ € 508,00
Kg 17,53
Vol 0,07

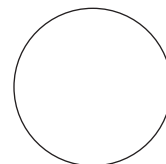

IT Su richiesta, come per mobili e lavabi, è possibile laccare esternamente le vasche in Tecnoril® Style e Soft 1 con i colori Cerasa.

EN Upon request, as for many other furnishing solutions and basins, the exterior of Cerasa Soft1 and Style basins in Tecnoril® is also available in a lacquered finish.

FR Sur demande, comme pour les meubles et les lavabos, les baignoires peuvent être laquées extérieurement en Tecnoril® Style et Soft 1 avec les couleurs Cerasa

STYLE
ZC KVS TL1 H0 P5
→ € 7209,00
Kg 126
Vol 0,73

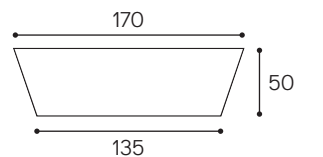

SOFT 1
ZC KVS FT1 K0 P5
→ € 6978,00
Kg 131
Vol 0,92

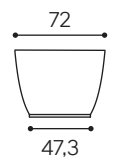
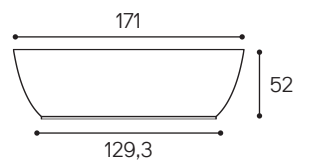

VASCHE

BATHTUBS/BAIGNOIRES

PARAVENTO E SERVOMUTO

FOLDING SCREEN AND VALET STAND
PARAVENT ET VALET



IT In accompagnamento al progetto Skinglass, Cerasa propone le inedite grafiche anche in versione tessuto per essere utilizzato nei particolari paraventi o nel servomuto con specchio presenti nella collezione DES. Si tratta di un tessuto in poliestere Made in Italy con caratteristiche di elevatissima resistenza conferite dall'esclusiva composizione della trama a 110 fili per pollice. Per la normale pulizia, utilizzare un panno inumidito con dell'acqua.

EN In addition to Skinglass, Cerasa offers new decorative patterns also on fabric for the screens or in the valet stand with mirrors included in the DES collection. The unique texture at 110 threads per inch of this Italian polyester fabric makes it particularly strong and resistant. For cleaning, use a cloth dampened with water.

FR Pour accompagner le projet Skinglass, Cerasa propose les graphismes inédits également en version tissu, pour une utilisation dans les paravents particuliers ou dans le valet avec miroir présents dans la collection DES. Il s'agit d'un tissu en polyester Made in Italy offrant des caractéristiques de très grande résistance, grâce à la composition exclusive de la trame à 110 fils par pouce. Pour le nettoyage, utiliser uniquement un chiffon doux imbibé d'eau.

↑ Collection
DES





Paravento/Folding screen/Paravent

DS AH0 836 01
Kg 20,10
Vol 0,02

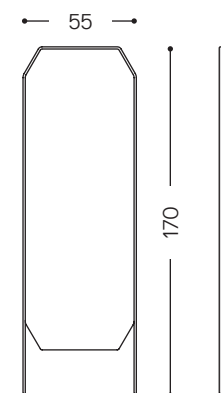

DS AH0 836 02
Kg 21,9
Vol 0,02

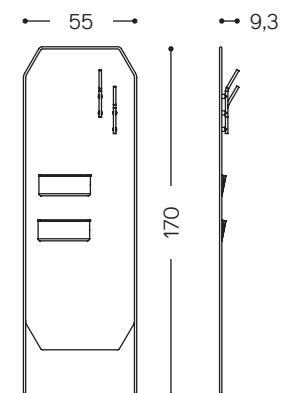

DS AH0 836 03
Kg 20,7
Vol 0,02

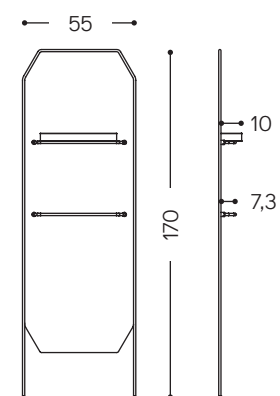

Servomuto/Valet stand/Valet

DS HJ4 835 55
Kg 35,90
Vol 0,40

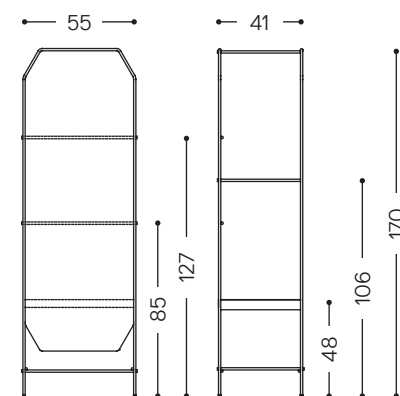

Per le quotazioni e tipologie, fare riferimento al listino DES
For prices and types, refer to DES price list
Pour les prix et les types, se référer au tarif DES



COLONNA

FULL-HEIGHT UNIT/COLONNE



IT Una nuova colonna per la collezione **CartaBianca**, un articolo contenitivo con ante rientranti, ripiani in cristallo e un praticissimo vassoio scorrevole. La colonna può essere personalizzata con l'inserimento delle maniglie MAN031, MAN034, MAN005, MAN033 poste tutte in verticale, oppure con il nuovissimo pomolo **POM 008** in acciaio godronato. **Il nuovo pomolo è utilizzabile senza alcuna maggiorazione in tutti gli articoli di CartaBianca, Misura e Regola.**

EN This new full-height unit for the **CartaBianca** collection offers much storage space, is fitted with sliding doors, crystal shelves and a convenient sliding tray. The unit can be customized with the handles MAN031, MAN034, MAN005, MAN033 all placed vertically, or with the brand new **POM 008** knob in knurled steel. **The new knob can be combined with all CartaBianca, Misura and Regola models without any surcharge.**

FR Une nouvelle colonne pour la collection **CartaBianca**, un article de rangement avec des portes rentrantes, des étagères en verre et un plateau coulissant très pratique. La colonne peut être personnalisée avec les poignées MAN031, MAN034, MAN005 et MAN033, toutes placées à la verticale, ou avec la toute nouvelle poignée **POM 008** en acier moleté. **La nouvelle poignée peut être utilisée sans aucune majoration dans tous les articles de CartaBianca, Misura et Regola.**

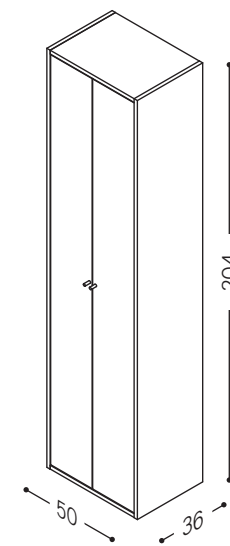

Basamento H 4 cm compreso
With plinth H 4 cm
Avec socle H 4 cm

CB CL3 164 50
Kg 95,50
Vol 0,61

**P1 Nobilitati/
Laminates/Stratifié**
→ € 1097,00

**P3 Laccato Bianco opaco/
Matt Bianco lacquered/
Laqué Bianco mat**
→ € 1428,00

**P4 Laccato Bianco lucido/
Glossy Bianco lacquered/
Laqué Bianco brillant**
→ € 1703,00

**P5 Laccato colore opaco/
Matt colour lacquered/
Laqué couleur mat**
→ € 1814,00

**P6 Laccato colore lucido/
Glossy colour lacquered/
Laqué couleur brillant**
→ € 1860,00

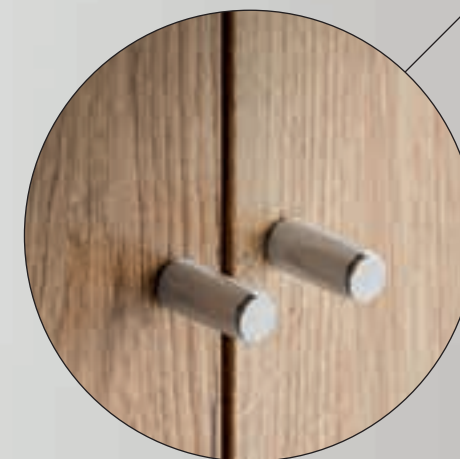

—> Frame è la nuovissima proposta Cerasa nel campo dei termoarredi. Si tratta di un esclusivo scaldasalviette elettrico che può essere anche inserito, con o senza l'uso del portasciugamano e dell'appendino, in altre stanze della casa proprio per il suo carattere distintivo e altamente decorativo. Due versioni per le finiture ma innumerevoli declinazioni, che sapranno rispondere ai gusti e alle esigenze più particolari: Frame in versione gres è personalizzabile con una selezione di lastre Laminam® e non solo; Frame in versione Skinglass permette di spaziare attraverso tutta la creatività delle grafiche proposte per l'innovativo rivestimento in fibra di vetro EQ•dekor®.

EN Frame is the brand-new offering by Cerasa in the range of heated towel racks. It is an exclusive electric towel rack that can also be placed in other rooms of the house, with or without towel holder and hangers, precisely because of its distinctive and highly decorative character. Available in two finishes but countless variations to meet the most diverse personal tastes and requirements: the gres version can be customised with a selection of Laminam® sheets, among other options; the Skinglass version offers a wide range of graphics that embody the sheer creativity behind our innovative EQ•dekor® fiber glass coating.

FR Frame est la toute nouvelle proposition Cerasa dans le domaine des radiateurs décoratifs. Il s'agit d'un sèche-serviettes électrique exclusif, qui peut aussi être inséré, avec ou sans porte-serviette et barre de penderie, dans d'autres pièces de la maison grâce à son caractère distinctif et hautement décoratif. Deux versions pour les finitions, mais d'innombrables déclinaisons, qui sauront répondre aux goûts et aux exigences de chacun : Frame en version grès peut être personnalisé avec une sélection de plaques Laminam®, mais ce n'est pas tout ; Frame en version Skinglass permet de disposer de toute la créativité des graphismes proposés pour le revêtement innovant en fibre de verre EQ•dekor®.

FRAME

DESIGN
LEONARDO DE CARLO

CO CERASA®



Terموارredo Frame/Frame heated towel racks/Radiateur décoratif Frame

Struttura

- Telaio in tubolare metallico 30 mm x 30 mm, verniciato a polvere in finitura Nichel.
- Portasalviette e appendino opzionali in metallo verniciato a polvere in finitura Nichel.
- Staffe antiganciamento e istruzioni di montaggio incluse.

Caratteristiche elettriche

- Grado di protezione IP44.
- Sistema riscaldante a resistenza 500 W - 50 Hz -230 V.
- Interruttore laterale DX/SX, a tocco, con spia luminosa e sistema di autoregolazione della resistenza che consente di mantenere la temperatura costante (max 65°C).
- In caso di surriscaldamento, un dispositivo di sicurezza blocca immediatamente il funzionamento dell'apparecchio.
- Cavo di alimentazione lunghezza 1,20 m, senza presa.
- L'impianto può essere implementato con l'installazione di un cronotermostato a cura del cliente.

Installazione

L'installazione deve essere effettuata da personale specializzato. L'apparecchio di riscaldamento deve essere installato in maniera tale che gli interruttori e gli altri dispositivi di comando non possano essere toccati da una persona presente nella vasca da bagno o sotto la doccia (rif. Norma NF C15-100). Non deve essere installato al di sotto di una presa elettrica.

Structure

- 30 mm x 30 mm metal tubular frame, powder-coated in Nickel finish.
- Optional metal powder-coated towel racks and hangers in Nickel finish.
- Anti-release brackets and assembly instructions included.

Electrical specifications

- IP44 Security.
- 500 W - 50 Hz -230 V resistance heating system.
- Right or left side touch switch, with indicator light and resistance self-regulation system, which allows keeping the temperature constant (max 65°C).
- In case of overheating, a safety device immediately causes the heater to switch off.
- Power cable of 1,20 metre in length, without socket.
- The system can be implemented with a chronothermostat, to be installed by the customer.

Installation

Installation must be performed by specialised personnel. The heating device must be installed in such a way that the switches and other control devices cannot be reached by a person while in the bathtub or shower (ref. NF C15-100). It should not be installed under an electric socket.

Structure

- Châssis en tube métallique 30 x 30 mm, peint par poudre en finition Nickel.
- Porte-serviettes et barre de penderie en option, en métal peint par poudre en finition Nickel.
- Pattes anti-décrochage et instructions de montage incluses.

Caractéristiques électriques

- Indice de protection IP44.
- Système de chauffage par résistance 500 W - 50 Hz - 230 V.
- Interrupteur tactile latéral droit ou gauche avec voyant lumineux et système d'autorégulation de la résistance, qui permet de maintenir la température constante (max 65°C).
- En cas de surchauffe, un dispositif de sécurité arrête immédiatement le fonctionnement de l'appareil.
- Cordon d'alimentation de 1,20 mètre de longueur, sans prise.
- Le système peut être implémenté avec un chronothermostat, à installer par le client.

Installation

L'installation doit être effectuée par du personnel spécialisé. L'appareil de chauffage doit être installé de manière à ce que les interrupteurs et les autres dispositifs de commande ne puissent pas être touchés par une personne se trouvant dans la baignoire ou sous la douche (réf. norme NF C15-100). Il ne doit pas être installé au-dessous d'une prise électrique.

Classificazione delle zone/Zone's classification/Classification des zones

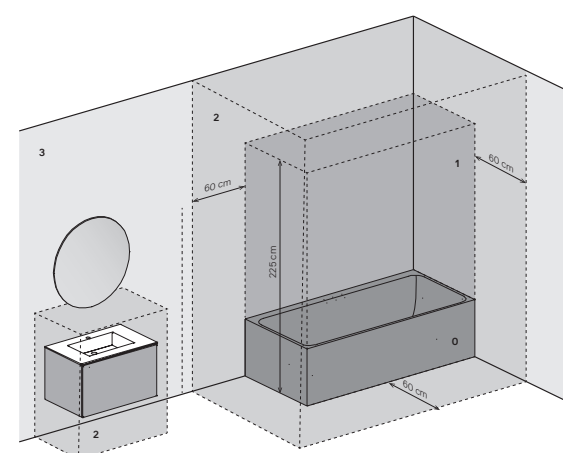

- Superficie fredda
Cold area
Surface froide

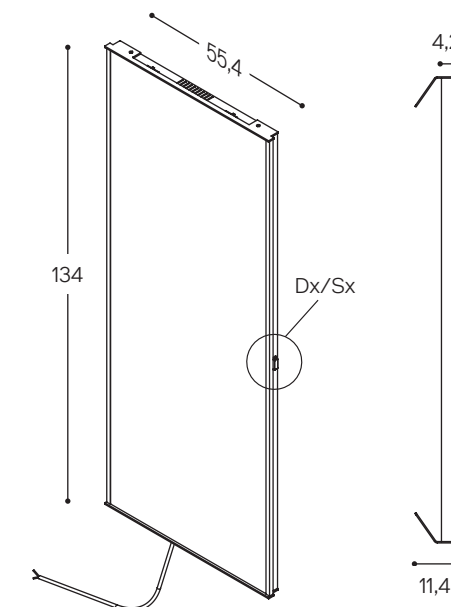
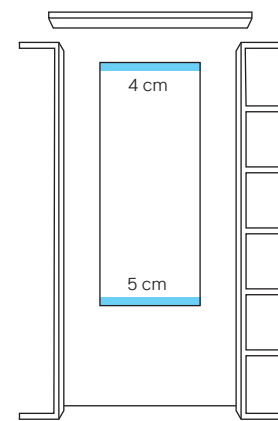

Frontali Frame/Frame fronts/Façades Frame



Laminam®-Gres

Lastra spessore 6 mm con bordi lucidati.
Sheet 6-mm-thick with polished edges.
Plaque épaisseur 6 mm avec bords polis.

ZC AD1 RAD 55
LO → € 1298,00
L1 → € 1395,00
L2 → € 1483,00
B1 → € 1395,00

Kg 15,50
Vol 0,04

Skinglass fibra di vetro EQ.dekor®

Lastra in vetro temperato spessore 6 mm con applicazione di carta da parati in fibra di vetro Skinglass e profili laterali a "L" spessore 1 mm verniciati a polvere in finitura Nichel.

EQ.dekor® fiber glass Skinglass

6-mm-thick toughened glass sheet with Skinglass fiber glass wallpaper and 1mm-thick L-shaped side profiles in powder-coated Nickel finish.

Skinglass fibre de verre EQ.dekor®

Plaque en verre trempé de 6 mm d'épaisseur, avec application de papier peint en fibre de verre Skinglass et de profilés latéraux en « L » de 1 mm d'épaisseur, peints par poudre en finition nickel.

ZC AD1 RAD 55
→ € 1623,00
Kg 15,50
Vol 0,04



Accessori Frame/Frame accessories/Accessoires Frame



Portasalviette

Verniciato a polvere finitura Nichel (posizionabile nella parte superiore e/o inferiore)

Towel holder

Powder-coated Nickel finish (suitable for top/bottom use)

Porte-serviettes

Peint par poudre finition Nickel (positionnable dans la partie supérieure et/ou inférieure)

ZC AP RR5 50199
→ € 95,00
Kg 2,00
Vol 0,01

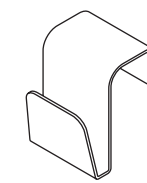
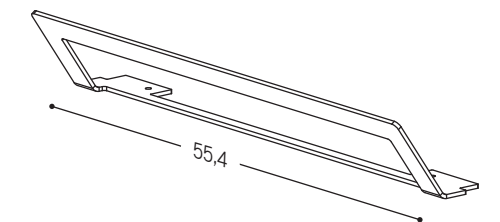

Appendino

Verniciato a polvere finitura Nichel (posizionabile a Dx e/o Sx)

Hook

Powder-coated Nickel finish (suitable for left/right use)

Patère

Peint par poudre finition Nickel (positionnable à Dr et/ou à Gh)

ZC AY TAR 00199
→ € 75,00
Kg 0,1
Vol 0,01



Laminam®-Gres

Disponibili per tutte le collezioni Cerasa
Available for all Cerasa collections
Disponibles pour toutes les collections Cerasa

LO - I NATURALI



Pietra Savoia Grigia Pietra Savoia Antracite Pietra di Savoia Perla Emperador Grigio**

LO - OSSIDO



Bruno Nero

LO - FOKOS



Roccia Terra

L1 - FILO



Argento* Rubino*

L1 - COLLECTION



Bianco Assoluto Nero Assoluto

L1 - I NATURALI



Calacatta Oro venato opaco Nero Greco opaco Noir Desir opaco Orobico Grigio opaco

B1 - GRES



Graniglia



Pietra Grey opaco Statuarietto opaco Bianco Statuario venato opaco

L2 - I NATURALI



Emperador Extra lucido Bianco Statuario venato lucido Calacatta Oro venato lucido Noir Desir lucido Pietra Grey lucido Statuarietto lucido



Ardesia Bianco a spacco Ardesia Nero a spacco

*Disponibile solo per frontali DES
*Available only for DES fronts
*Disponibile seulement pour façades DES

** Non disponibile per Frame
** Not available for Frame
** Non disponible pour Frame

Skinglass



DIAMOND MAGNOL GREENGLASS BAYOU



CORAL PEACOCK VESUVIO FLUID

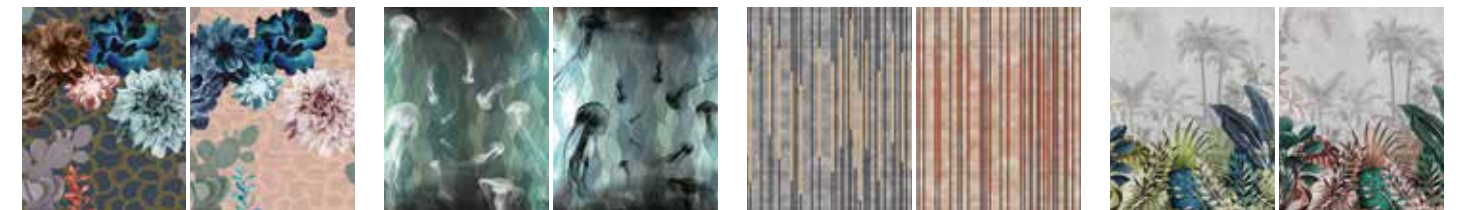

GEOFLO JELLYFISH VERTICAL RAINFOREST



RUST FLOWER PLANS FOLD



BLOSSOM GRAPHITE WATER LILY UNDERGROWTH



RUINS SHAPES LEAF

—→ Alla disponibilità di laccatura RAL opaca e lucida, senza maggiorazione di prezzo, da oggi si aggiunge una interessante tavolozza di colori personalizzati Cerasa: 28 nuove tinte, declinate nelle versioni opaco, lucido e SoftTouch, a cui si aggiungono 8 colori particolari.

COLOURS

WATERPROOF
DESIGN

EN In addition to the matt and polished RAL lacquered finishes, available without surcharge, an interesting palette of personalised Cerasa colours is now available: 28 new shades, available in matt, polished and SoftTouch versions, to which are added 8 special colours.

FR À la disponibilité du laquage RAL opaque et brillant, sans majoration de prix, vient s'ajouter à partir d'aujourd'hui une intéressante palette de couleurs personnalisées Cerasa : 28 nouvelles couleurs, déclinées dans les versions opaque, brillante et SoftTouch, avec en plus 8 couleurs spéciales.

 CERASA®

Gamma colori laccati/Lacquered finish range/Gamme de couleurs laquées

Disponibili per tutte le collezioni Cerasa
Available for all Cerasa collections
Disponibles pour toutes les collections Cerasa

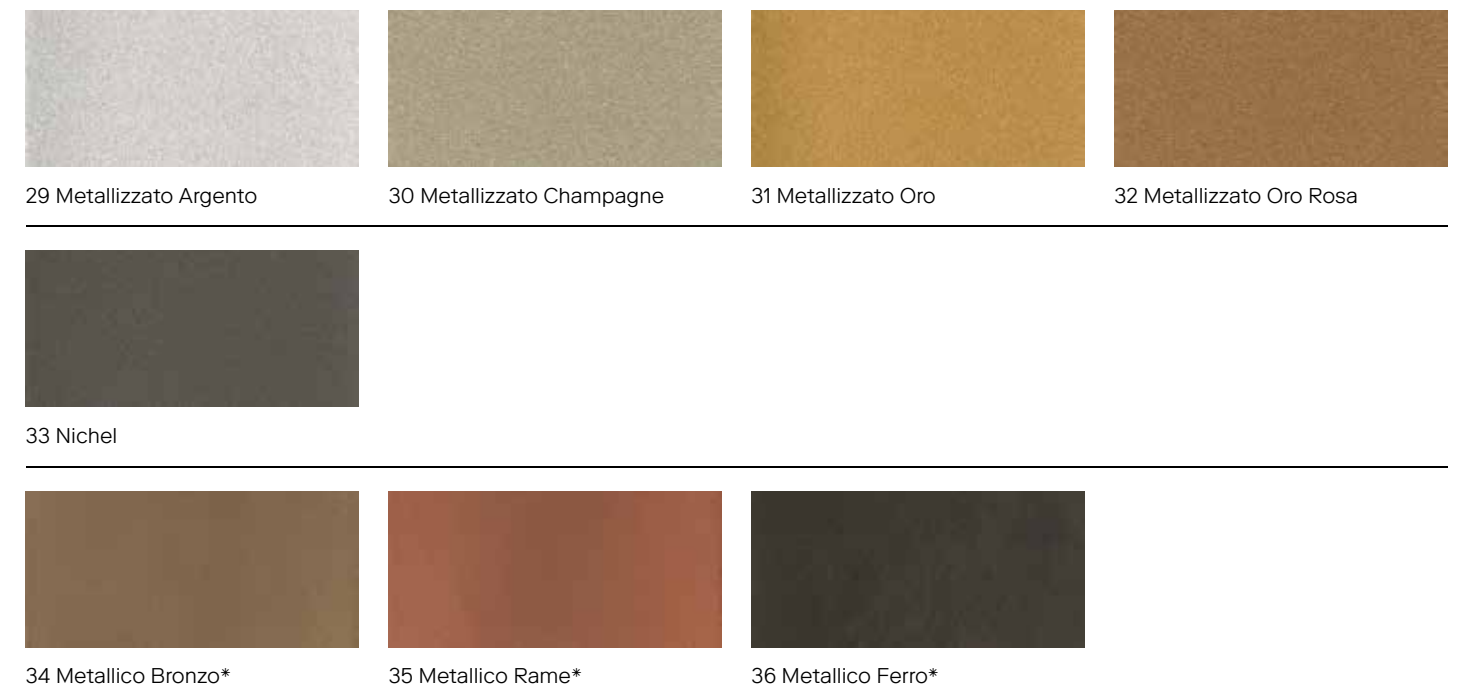

IT La finitura laccata è realizzata su una superficie liscia, disponibile in versione opaca e lucida. **Per le finiture metallizzate, si consideri la fascia di prezzo delle finiture laccate colore lucido.** Su richiesta, la laccatura SoftTouch può essere realizzata anche per le collezioni CartaBianca, Segno e NeroLab. Le tinte di questo campionario sono da ritenersi indicative.

EN The lacquered finish is realised on a plain surface, available both in matt and glossy version. **Metallic finishes are within the price range of glossy lacquered finishes.** On request, SoftTouch lacquering also for CartaBianca, Segno and NeroLab collections. These colours are to be considered indicative.

FR La finition Softtouch laquée est réalisée sur une surface lisse, disponible en version opaque et brillante. **Pour les finitions métallisées, prendre la tranche de prix des finitions laquées couleur brillante.** Sur demande, laquage SoftTouch aussi pour les collections CartaBianca, Segno et NeroLab. Les couleurs sont à considérer comme indicatives.

*Solo per Eden, Free e Maori
*Only for Eden, Free and Maori
*Uniquement pour Eden, Free et Maori

COLLECTIONS RECAP



P. 11
Collection: Single
85 46

Finiture/Finishes/Finitions:
Nobilitato Dogato Wood/
Dogato Wood Laminate/
Stratifié Dogato Wood
Lavabo/Basin/Vasque:
Unica



P. 12
Collection: NeroLab
56 44

Finiture/Finishes/Finitions:
Impiallacciato Eucalipto/
Eucalipto veneered/
Plaqué Eucalipto
Lavabo/Basin/Vasque:
Colonna



P. 15
Collection: CartaBianca
129 58.5

Finiture/Finishes/Finitions:
Nobilitato Dogato Color/
Dogato Color Laminate/
Stratifié Dogato Color
Piano/Top/Plan de toilette:
Laminam® Pietra Grey
Lavabo/Basin/Vasque:
Colonna Laccato opaco 17 Blu Polare/
17 Blu Polare matt lacquered/
Laqué mat 17 Blu Polare
Frame: Laminam® Pietra Grey



P. 16
Collection: NeroLab
75

Lavabo/Basin/Vasque:
Totem Skinglass Greenglass



P. 19
Collection: Segno
115 58.5

Finiture/Finishes/Finitions:
Nobilitato Dogato Color/
Dogato Color Laminate/
Stratifié Dogato Color
Piano/Top/Plan de toilette:
Ocritec Bianco opaco/
Matt Bianco Ocritec/
Ocritec Bianco mat
Lavabo/Basin/Vasque:
Colonna Skinglass Greenglass
Frame: Skinglass Greenglass

Riepilogo delle collezioni Ceresa presenti in questo catalogo/Summary of the Ceresa collections in this catalogue/
Résumé des collections Ceresa présentes dans ce catalogue



P. 21
Collection: DES
220 53

Finiture/Finishes/Finitions:
Impiallacciato Noce Chiaro e precomposto
Gessato/Noce Chiaro veneered
and Gessato composed veneered/
Plaqué Noce Chiaro et composé Gessato
Piano/Top/Plan de toilette:
Impiallacciato Noce Chiaro/
Noce Chiaro veneered/Plaqué Noce Chiaro
Lavabo/Basin/Vasque:
Icon



P. 22
Collection: NeroLab
198 51

Finiture/Finishes/Finitions:
Impiallacciato Rovere Chiaro e Laccato
opaco 33 Nichel/Rovere Chiaro veneered
and 33 Nichel matt lacquered/
Plaqué Rovere Chiaro et laqué mat 33 Nichel
**Mensolone/Top in high thickness/
Plan de toilette en grosse épaisseur**
Impiallacciato Rovere Chiaro/Rovere Chiaro
veneered/Plaqué Rovere Chiaro
Lavabo/Basin/Vasque:
Basic



P. 25
Collection: Eden
40 22.5

Finiture/Finishes/Finitions:
Laccato opaco 33 Nichel/
33 Nichel matt lacquered/
Laqué mat 33 Nichel
Lavabo/Basin/Vasque:
Cus



P. 28
Collection: NeroLab
193 51

Finiture/Finishes/Finitions:
Laccato opaco RAL 7031/
RAL 7031 matt lacquered/
Laqué mat RAL 7031
Piano/Top/Plan de toilette:
Deimos® Grigio
Lavabo/Basin/Vasque:
H2O



P. 31
Collection: NeroLab
150 51

Finiture/Finishes/Finitions:
Laccato opaco Bianco/
Bianco matt lacquered/
Laqué mat Bianco
Piano/Top/Plan de toilette:
Laccato opaco Bianco e Laminam® Statuarietto/
Bianco Matt lacquered and Statuarietto Laminam®/
Laqué Bianco mat et Laminam® Statuarietto
Lavabo/Basin/Vasque:
Stay



P. 34
Collection: Maori
210 53

Finiture/Finishes/Finitions:
Impiallacciato Eucalipto/
Eucalipto veneered/
Plaqué Eucalipto
Piano/Top/Plan de toilette:
Laminam® Noir Desir
Lavabo/Basin/Vasque:
Diamante



P. 37
Collection: DES
200 53

Finiture/Finishes/Finitions:
Laccato opaco RAL 9001 e Laminam®
Calacatta Oro/RAL 9001 matt lacquered
and Calacatta Oro Laminam®/
Laqué mat RAL 9001 et Laminam® Calacatta Oro
**Mensolone lavabo/Top in high thickness with
integrated basin/Plan de toilette en grosse
épaisseur avec vasque moulée:**
Laminam® Calacatta Oro



P. 38
Collection: Suede

Finiture/Finishes/Finitions:
Impiallacciato Noce Canaletto/
Noce Canaletto veneered/
Plaqué Noce Canaletto
Lavabo/Basin/Vasque:
Evam in Ecomalta® Taico



P. 41
Collection: Eden

Finiture/Finishes/Finitions:
Laccato opaco RAL 7002/
Ral 7002 matt lacquered/
Laqué mat RAL 7002
**Top Lavabo/Top with integrated basin/
Plan de toilette avec vasque moulée:**
Ecomalta® Sand



P. 42
Collection: DES

Finiture/Finishes/Finitions:
Laccato opaco RAL 1013 e Skinglass Vertical/
RAL 1013 matt lacquered and Vertical Skinglass/
Laqué mat RAL 1013 et Skinglass Vertical
**Top Lavabo/Top with integrated basin/
Plan de toilette avec vasque moulée:**
Ocritec Bianco opaco/Matt Bianco Ocritec/
Ocritec Bianco mat



P. 54
Collection: DES

Finiture/Finishes/Finitions:
Impiallacciato Noce Chiaro e Laminam®
Emperador Grigio/Noce Chiaro veneered
and Emperador Grigio Laminam®/Plaqué
Noce Chiaro et Laminam® Emperador Grigio
Piano/Top/Plan de toilette:
Laminam® Emperador Grigio



P. 57
Collection: DES

Finiture/Finishes/Finitions:
Impiallacciato Eucalipto e Skinglass Fold/
Eucalipto veneered and Fold Skinglass/
Plaqué Eucalipto et Skinglass Fold
**Top Lavabo/Top with integrated basin/
Plan de toilette avec vasque moulée:**
Ecomalta® Nebbia
Frame: Skinglass Fold



P. 58
Collection: Free

Finiture/Finishes/Finitions:
Laccato 34 Metallico Bronzo e Nero opaco
effetto poro aperto/34 Metallico Bronzo lacquered
and Nero matt lacquered open-pore effect/
Laqué 34 Metallico Bronzo et laqué Nero
mat pore ouvert
Lavabo/Basin/Vasque:
Smart



P. 45
Collection: Maori

Finiture/Finishes/Finitions:
Impiallacciato Eucalipto/
Eucalipto veneered/
Plaqué Eucalipto
**Top Lavabo/Top with integrated basin/
Plan de toilette avec vasque moulée:**
Laminam® Noir Desir



P. 47
Collection: DES

Finiture/Finishes/Finitions:
Impiallacciato Eucalipto e Cristallo sabbato
Grafite VS09/Eucalipto veneered
and VS09 Grafite frosted glass/
Plaqué Eucalipto et verre dépoli VS09 Grafite
Piano/Top/Plan de toilette:
Cristallo sabbato Grafite VS09/
VS09 Grafite frosted glass/
Verre dépoli VS09 Grafite
Lavabo/Basin/Vasque:
Stay



P. 61
Collection: DES

Finiture/Finishes/Finitions:
Impiallacciato Eucalipto e Ecomalta® Nebbia/
Eucalipto veneered and Nebbia Ecomalta®/
Plaqué Eucalipto et Ecomalta® Nebbia
**Top Lavabo/Top with integrated basin/
Plan de toilette avec vasque moulée:**
Ecomalta® Nebbia



P. 48
Collection: DES

Finiture/Finishes/Finitions:
Impiallacciato Eucalipto e Laminam® Terra/
Eucalipto veneered and Terra Laminam®/
Plaqué Eucalipto et Laminam® Terra
**Mensolone lavabo/Top in high thickness
with integrated basin/Plan de toilette
en grosse épaisseur avec vasque moulée:**
Ocritec Bianco opaco/
Matt Bianco Ocritec/
Ocritec Bianco mat
Frame: Laminam® Terra



P. 62
Collection: NeroLab

Finiture/Finishes/Finitions:
Laccato opaco Ral 7005/
RAL 7005 matt lacquered/
Laqué mat RAL 7005
**Mensolone/Top in high thickness/
Plan de toilette en grosse épaisseur**
Corteccia Viva
Lavabo/Basin/Vasque:
Prince 2



P. 63
Frame: Laminam® Nero Greco



P. 51
Collection: NeroLab

Finiture/Finishes/Finitions:
Impiallacciato Eucalipto/
Eucalipto veneered/
Plaqué Eucalipto
**Top Lavabo/Top with integrated basin/
Plan de toilette avec vasque moulée:**
Tecnoril®
Frame: Skinglass Flower



P. 52
Collection: DES

Finiture/Finishes/Finitions:
Laccato opaco 01 Ghiaccio/
01 Ghiaccio matt lacquered/
Laqué mat 01 Ghiaccio
**Mensolone lavabo/Top in high thickness
with integrated basin/Plan de toilette
en grosse épaisseur avec vasque moulée:**
Tecnoril®



P. 64
Collection: NeroLab

Finiture/Finishes/Finitions:
Laccato opaco Bianco/
Bianco matt lacquered/
Laqué Bianco mat
Piano/Top/Plan de toilette:
Impiallacciato Rovere Chiaro/
Rovere Chiaro veneered/
Plaqué Rovere Chiaro
Lavabo/Basin/Vasque:
Pixie



P. 67
Collection: Free

Finiture/Finishes/Finitions:
Frassino tinta legno/
Wood colour ash/
Frêne couleur bois
Lavabo/Basin/Vasque:
Smart



 53
225

P. 69
Collection: DES

Finiture/Finishes/Finitions:
Impiallacciato Eucalipto e Skinglass Undergrowth/
Eucalipto veneered and Undergrowth Skinglass/
Plaqué Eucalipto et Skinglass Undergrowth
**Top Lavabo/Top with integrated basin/
Plan de toilette avec vasque moulée:**
Tecnoril®



 53
105

P. 70
Collection: DES

Finiture/Finishes/Finitions:
Impiallacciato Eucalipto/
Eucalipto veneered/
Plaqué Eucalipto
Piano/Top/Plan de toilette:
Impiallacciato Eucalipto/
Eucalipto veneered/
Plaqué Eucalipto
Lavabo/Basin/Vasque:
Speen



 51
105

P. 73
Collection: NeroLab

Finiture/Finishes/Finitions:
Laccato lucido Bianco/
Bianco glossy lacquered/
Laqué Bianco brillant
**Mensolone lavabo/Top in high thickness
with integrated basin/Plan de toilette
en grosse épaisseur avec vasque moulée:**
Deimos® Nero



 51
95

P. 77
Collection: NeroLab

Finiture/Finishes/Finitions:
Laccato opaco 33 Nichel/
33 Nichel matt lacquered/
Laqué mat 33 Nickel
Lavabo/Basin/Vasque:
Monolite Alto



 51
150

P. 80
Collection: NeroLab

Finiture/Finishes/Finitions:
Laccato opaco Bianco/
Bianco matt lacquered/
Laqué Bianco mat
**Mensolone/Top in high thickness/
Plan de toilette en grosse épaisseur:**
Laminam® Statuarietto
Lavabo/Basin/Vasque:
Martin 1
Frame: Laminam® Statuarietto



 46
95

P. 92
Collection: Single

Finiture/Finishes/Finitions:
Nobilitato Pietra/
Pietra laminate/
Stratifié Pietra
Lavabo/Basin/Vasque:
Unica



 36
50+50

P. 93
**Colonne/Full-height units/
Colonnes:** CartaBianca

Finiture/Finishes/Finitions:
Laccato opaco 05 Grigio Cemento/
05 Grigio Cemento matt lacquered/
Laqué mat 05 Grigio Cemento



 44
56

P. 102
Collection: NeroLab

Finiture/Finishes/Finitions:
Laccato opaco Bianco/
Bianco matt lacquered/
Laqué Bianco mat
Lavabo/Basin/Vasque:
Colonna Skinglass Vertical



 44
56

P. 105
Collection: NeroLab

Finiture/Finishes/Finitions:
Laccato opaco Ral 9005/
RAL 9005 matt lacquered/
Laqué RAL 9005 mat
Lavabo/Basin/Vasque:
Totem Skinglass Shapes
Frame:
Skinglass Shapes



 58.5/
36
115

P. 110
Collection: Segno

Finiture/Finishes/Finitions:
Nobilitato Coast/Coast laminate/
Stratifié Coast
Piano/Top/Plan de toilette:
Nobilitato Coast/Coast laminate/
Stratifié Coast
Lavabo/Basin/Vasque:
Colonna
Frame:
Laminam® Ardesia Bianco a spacco

Design Direction
Leonardo De Carlo

Graphic Design
Metodo studio

Images
Fotografica
Inkiostro Bianco

Color separation
GM Studio1

Copywriting
Metodo studio

Printing
Grafiche Antiga

Per le condizioni generali
di vendita, fare riferimento
ai listini Sistema.

For general conditions
of sales, please refer
to the Sistema price lists.

Pour les conditions générales
de ventes, veuillez vous
référer aux listes de prix
du Sistema.

CERASA S.P.A.

via Borgo Nobili, 19
31010 Bibano di Godega
di S. Urbano (TV) Italy
Ph. +39 0438 783411
Fax +39 0438 783450
info@cerasa.it
www.cerasa.it

