

# Chalfont



wall hung



Chalfont Wall Hung 750 x 500 in Chrome with Crosshead valves

## Overview

Made in England  
1 model in hydronic or electric



## Finish

Chalfont Hydronic: Chrome  
Antique Bronze  
Antique Copper  
Bright Nickel

Chalfont Electric:  
Chrome only

# Linton Towel Rail

## Overview

Steel tubes with a cast iron radiator  
10 year guarantee, CE approved & certified to BS EN442

## Finish

Chrome with White RAL 9016 cast iron sections



Model	Height (mm)	Width (mm)	Watts $\Delta t$ 50°C	Btu's $\Delta t$ 50°C
LINTR904903CW	900	490	402	1372
LINTR906505CW	900	650	612	2088
LINTR908207CW	900	820	821	2801
LINTR104903CW	1000	490	482	1645
LINTR106505CW	1000	650	736	2511
LINTR124903CW	1200	490	633	2160
LINTR126505CW	1200	650	968	3303

Pipe centres left to right	Pipe centres from wall	Depth from wall
width - 122mm (+/- 2mm) - valves	140mm	315mm

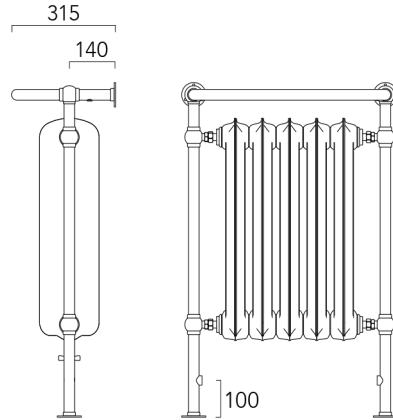

# Chalfont Wall Hung

## Overview

Brass tubed wall hung design, suitable for a direct system  
5 year guarantee, CE approved & certified to BS EN442



## Finish

Chrome (main image)  
Antique Bronze  
Antique Copper  
Bright Nickel



Antique Bronze



Antique Copper



Bright Nickel



## Hydronic

Model	Height (mm)	Width (mm)	Watts $\Delta t$ 50°C	Btu's $\Delta t$ 50°C
CHAL7550	750	500	169	577

Pipe centres left to right	Pipe centre from wall	Maximum depth from wall
width - 75mm	50mm	125mm

Electric

Model	Height (mm)	Width (mm)	Watts $\Delta t$ 50°C
CHAL7550E	750	500	100

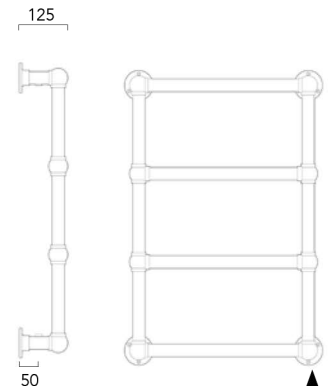

Position of element for electric models